

WHERE TO GET THE BEST HEAD

# IND **MOTOCROSS**

34485

**ACTION** MAGAZINE

**MEXICO'S  
GRAN PREMIO  
DE MX**

JANUARY 1976

\$1.00

UK40p

**NEW  
CHAMPS:  
WORLD &  
NATIONAL**

**RACE TEST:  
CAN-AM  
125**

**TWO 500 NATIONALS:  
OHIO & LOUISIANA**

**1976 ROY AWARD BALLOT**

RETAILERS: See page 74 for special display allowance plan.





## Plain geometry.

Hodaka handling is a matter of geometry. The bike becomes greater than the sum of its parts. The way those parts fit and perform together produces instant, precise, and predictable response.

No Hodaka has this geometry down any better than our out-of-the-crate 100cc racing machine, the Hodaka Super Rat MX. It goes where you point it and *fast*, with no surprises unless you're surprised at being out front. Great power, super suspension, reed valve induction, 28mm Mikuni racing carb, rim locks, heavy duty racing chain, 36" handlebars (cut 'em shorter if you want), 2-

position alloy rear shocks with cooling fins, plastic fenders—these and other performance features come together in a full size 100cc, the Hodaka Super Rat 100 MX, a forgiving but flat-out motocrosser.

If 100cc racing is your thing and you want to improve your lap times, check out the Hodaka Super Rat 100 MX. For free literature and your dealer's name, call the 800 telephone number. If your bag is 125cc MX, ask about the Hodaka Super Combat.

**HODAKA**<sup>®</sup>  
Handles



Super Combat 125   Dirt Squirt 100   Super Rat 100   **The Handlers**   Road Toad 100   250   Combat & Wombat 125

### FREE TELEPHONE NO. 800-547-8120

Call this number for the name and address of your nearest Hodaka dealer. Or check the Yellow Pages or write PABATCO, Box 327, Athena, Oregon 97813.

Canadians: Gemini Ind., Vancouver, B.C.  
Australians: Sport & Road Pty., Ltd., Box 209 S. Melbourne, 3205



Hodaka Super Rat 100cc MX.

# MOTOCROSS

VOLUME FOUR  
NUMBER ONE

## ACTION

MAGAZINE

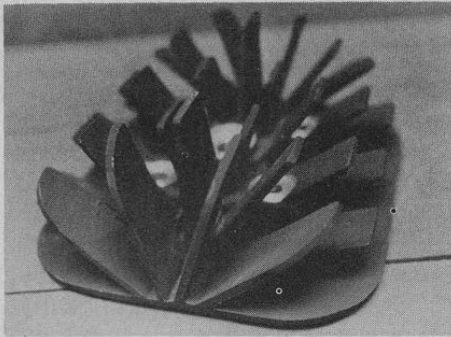

HEAD TEST



CAN-AM 125 TEST

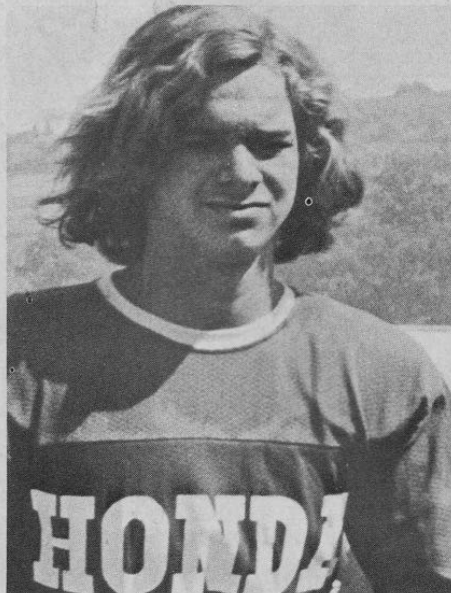

1975 CHAMPIONS

editor  
DICK MILLER  
managing editor  
MIKE KERLEY  
associate editor  
PAUL BOUDREAU  
art director  
MAURICE E. GOLDMAN  
contributing editors  
PETE SZILAGYI  
JIM RUSSELL  
european correspondent  
DAVID MALTAIS  
test consultants  
PETE MALY  
AL BAKER  
advertising coordinator  
ALBETH GRASS  
production editor  
GEORGIA McCLAY  
typographer  
JEANETTE G. HARVEY

## MACHINES

- 44 CAN-AM 125 MX-2**  
*Out-of-the-box power and the sturdiness of a small bore buffalo make the MX-2 a tempting choice for the racer who likes to go stock*

## EVENTS

- 20 500 NATIONAL, RAVENNA, OHIO**  
*Grossi takes over the lead in the National Championship Series with one event to go*
- 50 500 NATIONAL, NEW ORLEANS, LOUISIANA**  
*You almost needed a flashlight to determine the outcome of one of the most exciting National Championship MX battles in the AMA's history*

- 56 MEXICO'S GRAN PREMIO de la AMISTAD**  
*Is it a race or a party?*

## FACTS

- 17 ROY AWARD BALLOT FOR 1976**  
*Cut it out and vote*
- 26 GETTING YOUR HEADS STRAIGHT**  
*A test and comparison of popular accessory cylinder heads*
- 32 WORLD AND NATIONAL MOTOCROSS CHAMPIONS — 1975**  
*A quick look at the big six*

## FANCIES

- 4 ON THE MAINJET**
- 6 BAZ'S BOX**
- 8 DIRT**
- 12 WRENCH WRACING**
- 14 MAIL ENTRIES**
- 16 WHIPS**
- 18 TRICKS FROM THE TRADE**
- 78 BERM SHOT**

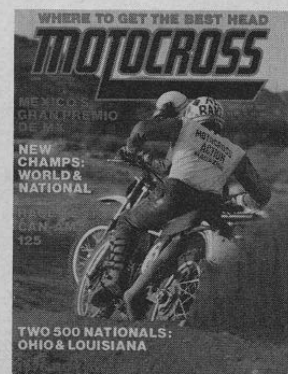

Test rider Al Baker bursts berm aboard Can-Am's potent 125 MX-2, as the Buzzer looks on in dismay. Photo by Dick "Click" Miller.

# ON THE MAINJET

By DICK MILLER

Dear MOTOCROSS ACTION,  
 Ever since I read your first issue of MOTOCROSS ACTION Magazine every time I hear someone say motorcross I drop the "R" and dot their eye for them. Unfortunately they usually dot mine back. What's the matter, don't they know it's for their own good?

Ron Laster  
 Fenton, Missouri

MOTOCROSS is spelled without the "R." It should be in Webster's Seventh New Collegiate Dictionary between the words mot-mot and motoneuron, which immediately precede the word we are all familiar

*Motorcross Action  
 16200 Ventura Blvd.  
 Encino, Ca 91316*

*Dick Miller - Motor Cross  
 162 Ventura Blvd.  
 Encino, Ca. 91436*



AMERICAN HONDA MOTOR CO., INC.  
 P. O. BOX 50 - 100 W. ALONDRA BLVD., GARDENA, CALIF. 90247  
 CABLE ADDRESS - AMEHON, GARDENA, CALIF. (213) 321 - 8680

TO: Motorcross Action  
 Attn: Dick Miller  
 Hi-Torque Publications, Inc.  
 16200 Ventura Blvd  
 Encino, CA 91316

New Products Editor  
 MOTORCROSS ACTION  
 16200 Ventura Blvd.  
 Encino, Calif. 91316

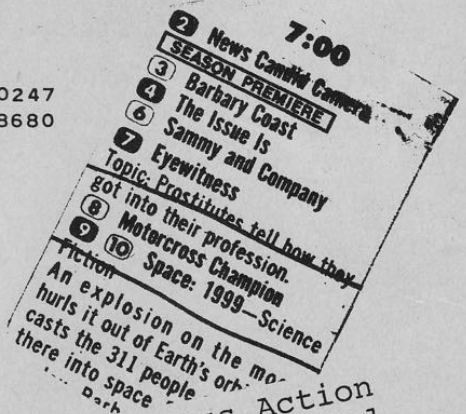

Motor Cross Action  
 16200 Ventura Blvd.  
 Encino, CA 91316

Motor Cross Action  
 Hi-Torque Publication, Inc.  
 16200 Ventura Blvd.  
 Encino, Calif. 91436

Motorcross Action  
 16200 Ventura Blvd.  
 Encino, Calif. 91316

## YAMAHA INTERNATIONAL CORPORATION INTER-OFFICE MEMORANDUM

The monocross suspension units as they come from the factory are just right for expert riders. The Y.I.C. motorcross racing team as well as several other name experts were pleased with the handling of stock suspension settings.

MOTORCROSS ACTION  
 16200 Ventura Blvd.  
 Encino, Calif. 91316

Motorcross Action  
 16200 Ventura Blvd.  
 Encino, CA 91316

To whom it may concern:

We are very interested in what is happening in High School motorcross.

A bunch of guys, are interested in starting a motorcross team,

**HI-TORQUE PUBLICATIONS, INC.**

President  
**WILLIAM R. GOLDEN**  
 VP/Advertising Director  
**JOHN SFERRA**  
 Promotion/Production  
 Director  
**LEW ROTH**  
 Circulation Director  
**KASS MASSEY**  
 Customer Relations  
**NANCY PAYNE**  
 Business Manager  
**S. F. GREEN**

Publisher's Lab  
**JOHN SPISHAK, Supervisor**

**ADVERTISING AND EDITORIAL OFFICES**  
 Hi-Torque Publications, Inc.  
 16200 Ventura Blvd.  
 Encino, California 91436  
 (213) 981-2317

**THE PATTIS GROUP**



**CHICAGO:**  
 4761 Touhy Ave.  
 Lincolnwood, IL 60646  
 (312) 679-1100

**NEW YORK:**  
 274 Madison Ave.  
 New York, NY 10016  
 (212) 679-7766

**CANADA:**  
 3286 Cavendish Blvd.  
 Montreal, PQ H4B 2L9  
 (514) 482-1454

**MOTOCROSS ACTION** (Jan. '76) is published monthly (semi-monthly in Sept.) by Hi-Torque Publications, Inc., with editorial offices at 16200 Ventura Blvd., Encino, California 91436. Subscriptions \$9.00 for 12 issues. Foreign \$2.00 additional for postage (Canada add \$1.00). Copyright © 1975 by Hi-Torque Publications, Inc. All rights reserved. Nothing in this magazine may be reprinted in whole or in part without the express permission of the publisher. Manuscripts, photographs and illustrations should be accompanied by a stamped, self-addressed envelope. The publisher does not assume responsibility for unsolicited material. Second class postage paid at Van Nuys, California 91408, and at additional mailing offices. **MOTOCROSS ACTION MAGAZINE**, P. O. Box 317, Encino, California 91316.

with, motorcycle! The word motorcycle is the most probable reason for the misspelling of motocross. One goes with the other, right? If you spell motorcycle with an "r" after moto, then why not motocross?

As far as I've been able to determine, motocross originated as a sport, at least seriously, in England. However, they didn't call it motocross. The English name for the sport was Scrambles. The French tagged the name of motocross to the sport and it stuck. The French word for motorcycle is moto, with cross meaning across the ground, rough terrain or whatever.

It's a natural mistake to misspell the word, especially if you don't know what a motocross is and had to look it up in a dictionary only to find that there is no definition. I hope to change all that and hereby commit myself to a campaign for the true recognition and correct spelling of **MOTOCROSS**. If you want to help, you can start by writing Webster's Dictionary at G&C Merriam Co., Springfield, Massachusetts, U.S.A. With any luck at all, they'll spell it right.

**Fast Track to a Cool Job!**

**★ TRAIN AT HOME TO BE A Motorcycle Mechanic**



If you like to ride a cycle for fun... learn how to fix it for profit! Can you imagine a better way to earn your living? And to make it even better, the pay is great - whether you choose to work in a cycle shop for someone else or decide to start your own cycle repair business. Now, thanks to North American, there's a fast, easy way to get the training you need... **at home in your spare time.** No need to quit school or your job. Experts show you step-by-step everything from minor tune-ups to major overhauls.

**CYCLES ARE BIG BUSINESS... AND SO IS FIXING THEM!**

There are more than 3 million cycles registered in the U.S. today. Plus an estimated 3 million more dirt bikes. But, there are fewer than 10,000 motorcycle mechanics available to repair them. (Imagine only one mechanic for every 600 motorcycles!) No wonder career opportunities are so great... and getting better every day. The door is open to you now. Rush coupon for FREE "Motorcycle Mechanic Career Kit."

**SPECIAL CYCLE TOOLS & TEST INSTRUMENTS INCLUDED TO START YOU FAST!**

Professional tools plus your North American "know-how" turn you into a skilled mechanic. We teach you how to use wrenches, sockets, impact screwdrivers, timing lights, electrical test instruments, compression gauges, vacuum gauges, degree wheels, soldering irons, ignition wrench sets, dial indicators and much, much more! We even include a set of special cycle tools and instruments to get you started fast! Find out all about it now. Send for FREE "Motorcycle Mechanic Career Kit." No cost, no obligation... now or ever! Rush coupon today.



Careers by Home Study  
**NORTH AMERICAN SCHOOL OF MOTORCYCLE REPAIR**  
 4500 Campus Drive, Dept. FE005 Newport Beach, CA 92663  
 Rush FREE "CAREER KIT" on how I can become an expert motorcycle mechanic.

NAME \_\_\_\_\_ AGE \_\_\_\_\_  
 ADDRESS \_\_\_\_\_  
 CITY \_\_\_\_\_ STATE \_\_\_\_\_ ZIP \_\_\_\_\_

**RIDER'S CHOICE** P.O. BOX 15313 Long Beach, CA 90815

quantity \$1.75 **AC GAS FILTERS**



"Came out #1 in filter shootout"

quantity \$5.95 **BARUM "BIG RED" TUBES**

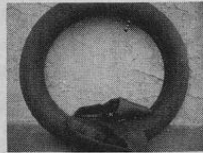

400x18 EXTRA heavy duty; used in International Six Day Trials

quantity ONLY \$6.90 10 per box.

Standard **NGK PLUGS**



quantity \$7.95 **QUALITY FORK BOOTS**

Black\_\_\_\_  
 Red\_\_\_\_  
 Yel\_\_\_\_  
 Blue\_\_\_\_

Extend fork seal life, protect front fork legs.

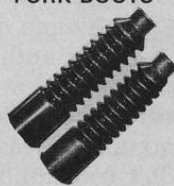

quantity \$2.65 pair

**FOAM FORK PROTECTOR**

Black\_\_\_\_ Red\_\_\_\_ Yel\_\_\_\_ Blue\_\_\_\_

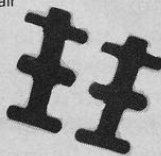

quantity \$7.95

**"SNAP-ON" ROCK GUARD for SCOTT GOGGLES**



Send check or money order, plus \$1.00 for handling and shipping. Calif. residents add 6% sales tax.

Ship to: Name \_\_\_\_\_  
 Address \_\_\_\_\_  
 City \_\_\_\_\_  
 State \_\_\_\_\_ Zip \_\_\_\_\_

**PROTEC CHAIN TENSIONER**

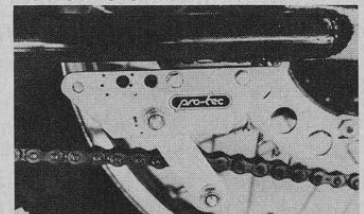

All new functional, heavy-duty CHAIN GUIDE/TENSIONER. High test spring loaded Teflon rollers keep chain taut while flexible. Angle of mount acts as chain guide and prevents mud and brush from getting into rear sprocket.

\$19.95

- CT-1 CZ 250-400 '72-'75
- CT-2 CR 125 '73-'74
- CT-3 CR 125 '75
- CT-4 CR 250 '73-'74
- CT-5 CR 250 '75
- CT-6 MT 250 '73-'74
- CT-7 XL 250-350 '74-'75
- CT-8 HUS 250-400-450 '70-'74
- CT-9 SUZ RM125 '75
- YAM 100-125-250-360-400-500 MX & YZ '72-'75
- CT-10 SUZ TM250-400 '74-'75
- CT-11 YAM DT250-400 '68-'75
- CT-12 HUS 250-360 '75
- CT-13 BUL 250-360 '75
- CT-14 SUZ RM250-370 '75



High quality chrome moly tubing, finished in industrial chrome.

- ONLY \$18.95
- CZ
  - Husky/late
  - Husky/early
  - Low Maico
  - G.P. (Honda)

**ANDRE HANDLEBARS**

**New BOGE-MULHOLLAND SHOCKS & SPRINGS**



\$49.95 pr. (shocks)

- 10 3/4
  - 11 1/4
  - 12 1/4
  - 13
  - 13 1/2
  - 14
- Specify length of shock

\$13.95 pr. (springs)

- 50 lbs.
- 60 lbs.
- 78 lbs.
- 90 lbs.
- 110 lbs.
- 120 lbs.
- 135 lbs.
- 60/90
- 80/100
- 90/120

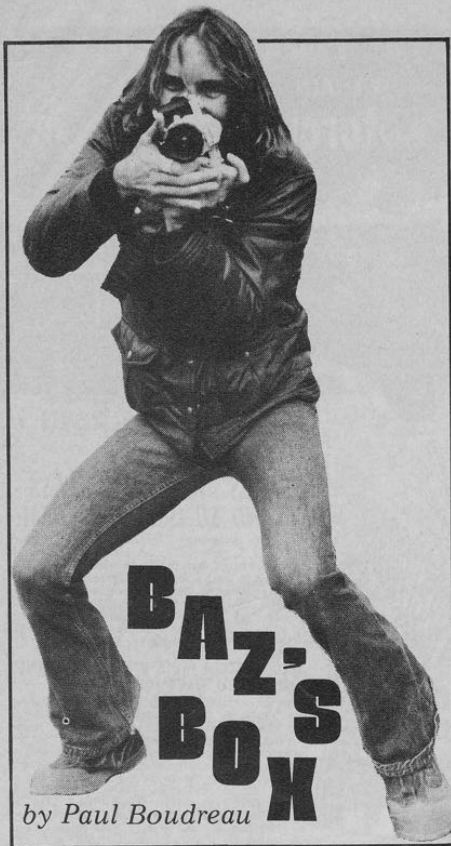

by Paul Boudreau

What a major. I'm leaving for the Trans-AMA in five days and in those five days I have to get a camper shell for the Bazmobile, four new tires and wheels, a set of shocks, the seat needs upholstery, the stereo has to be fixed, I have to pick up my camera from the repair shop and I've got to get a new bag for my waterbed because it sprung a leak and my kitchen looks like a water truck drove through it. Plus I have to write all my stuff for this month's issue and next month's because I'm going to be gone for five weeks. So what am I doing laid back on the veranda of a posh resort mobile home perched on the cliffs of Granada Cove just north of Ensenada, Mexico, watching my foxy lady brush her hair and listening to the blue Pacific pound against the rocks? Because that's what Mexico is for: doing nothing.

On the other hand, my partner Dick Miller feels Mexico is for activities more strenuous than sipping Coronas and soaking in the sun. He happens to be in Ensenada this weekend too, but he's here to partake in a bizarre yearly ritual practiced by that strange cult of motorcycle freaks known as Off Road Racers, or, as I like to call them, the "Baja Blasters." Every year around this time the Blasters come here to do something called a "pre-run." What they're doing is practicing for the Baja 1000, that grueling race over 800 or so miles of

the gnarliest terrain in the Western Hemisphere. Can you imagine? They're actually going to *practice* berserking 800 miles up and down the Baja on motorcycles! That's like practicing football against a team of polar bears.

I know. I've been around the Baja. The best way of getting from one place to another in the Baja is to be completely anesthetized with Margaritas, packed in foam and shipped by refrigerated air freight. It's rugged down here. After Ensenada, there's nothing but mountains, dry lakes and volcanic rock till you reach the resort city of La Paz on the southern tip of the peninsula. The few fishing villages and *ranchos* along the way are connected by a single paved road, and a sparse network of vaguely marked and casually maintained dirt roads. Actually, the "improved" dirt roads are the ones that are maintained by people getting out of their vehicles to move a rock in order to get by, and the regular-type dirt roads don't get the benefit of this user maintenance program because to get out of your car to move a rock would be sure death at the hands of the midday sun. Besides, most of the regular dirt roads are only distinguished from their surroundings by black marks left by the tires of other cars driving over the solid granite and an occasional dark stripe along the ground dotted at the end with a pool of oil commemorating the event of some poor farmer's '53 *Ch-ey* cracking its crankcase open like an egg against a hidden rock. Many places the road just stops happening and you have to follow the wide spaces that run between the bigger rocks. At times the road is merely a general direction.

The Baja Blasters don't use the paved road much, or the improved dirt roads or even the regular dirt roads. They like to use the "general directions." They're all crazy. They take a beautiful motorcycle like a Husqvarna 360, saddle it with a bulbous four-gallon gas tank and lights, and bolt, weld, hose-clamp or duct-tape on an assortment of tools, spare parts and survival gear that would match the capabilities of a Himalayan expedition. Most ride the Huskys, but some, like the Dempsey brothers, ride mighty Triumphs and some, like Miller and Al Baker, ride frighteningly stock Hondas. They even have a Vespa team. But no

matter what kind of bike it starts off as, it must feel like you're riding a 300-pound oil drum when it's finished.

You have to understand the Baja Blaster before you can understand his bike. After a day of testing on a motocross track like Indian Dunes, Miller and I might be sitting around bullshitting about the day's riding. "Boy, Dick," I'll say. "Did you see that neat line develop on the inside of that left down at the other end of the track by the tree?"

"Yeah, but I didn't like it. You had to shut off too much for it and I don't like to shut off. I like to hold it wide-open all the time," he replied, flashing a bent wrist.

"But Dick," I said, "in motocross one attempts to find the smoothest line. My line went across flat ground. Your line hit all those nasty bumps."

"What bumps?" He looked genuinely surprised. "I didn't see any bumps."

The Blaster's butt is completely insensitive to anything less than a major ravine or cross drainage ditch, and he knows no other speed than full-on nor any other direction than straight ahead. The subtleties of motocross escape him. He uses the first five gears of a six-speed gearbox only as a means of attaining the final gear. His fist holds the throttle, that fine tuning instrument of the artful motocrosser, locked in the mainjet position as solidly as a cotter pin inserted for that purpose. His jaw set, his eyes clamped to the speeding spot split seconds ahead, he aims his oil drum across the surface of the moon. I wonder what he thinks about.

So I told Al Baker I was going down to Ensenada for the weekend. "Bitchin! You gonna pre-run with Dick and Gunnar and me?"

"No, I'm going down with some friends and we're just going to lie around and take life easy," I replied.

"Wouldn't you rather go riding?" Al Baker is a true disciple of the sport.

I thought for a moment of the Baja with its searing stone terrain chipped to shrapnel by time and weather, populated only by sweltering lizards and a few skinny coyotes with tails like bottle brushes, and of what happens to the Blaster when his oil drum hits a big rock on the mainjet in sixth gear. No thanks, Al. *Uno mas cerveza, por favor.* III

# HONDA

## Motocross

### Buyers' Guide from



(213) 530-4656



#### Heavy Duty Bronze Swingarm Bushings

These replacement swingarm bushings are precision machined from solid bronze to insure a snug fit between swingarm and bolt. Resists wear and maintains wheel alignment for improved handling. Available for

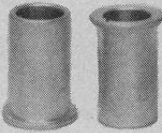

Honda CR 125 \$10.95  
Honda CR 250 \$11.95

#### Porcupine Cylinder Head

Unique design provides 18% more heat radiating surface area than stock cylinder head but with less weight. FMF Porcupine head keeps power loss due to heat build-up to a minimum. Hi-compression FMF combustion chamber increases engine performance. Bolts on stock or modified engines. Available for

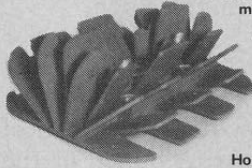

Honda CR 125 \$56.95

#### Marty Smith Replica Engine Kit

For 1973-1975 CR 125 Hondas, this engine kit produces up to 30% more H.P. Your stock '73 or '74 cylinder will be ported and a boost port added. Your piston will be precision machined to match the new boost port. FMF completes the kit with a Porcupine cylinder head, 32mm Mikuni carb and manifold, and competition pipe tuned to match the cylinder porting. Kit bolts on. Call or write FMF for your machine shop service appointment. Now available for the 1976 model.



\$275.90

#### CR125 Air Box Assembly

Large capacity, water resistant, air box bolts on in minutes. Air box comes complete with a double layer re-useable foam air filter element and all mounting hardware for bolt-on installation.

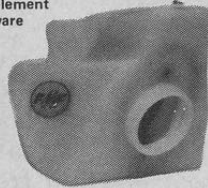

\$39.95

#### 100cc Sleeve Down Kit for 125cc CR

All the advantages of a smooth handling 125cc chassis can now be used in the 100cc class and comes complete with aluminum piston, special rings, cast iron cylinder sleeve and FMF hi-compression Porcupine head with gasket. Honda CR cylinder may be boost ported for additional performance. Specify when ordering. Honda cylinder, boost porting or standard porting. Call or write FMF for your machine shop service appointment. Sleeve Down Kit CR 125 Std. porting \$240.98  
Sleeve Down Kit CR 125 Boost porting \$285.98



#### Air-Oil Suspension Conversion

Special sealed fork caps allow front forks to be filled with air without removing handlebars. Available for

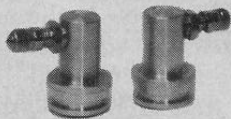

74 CR 125 \$14.95  
75 CR 125 \$ 9.95  
74 CR 250 \$15.95  
75 CR 250 \$ 9.95

#### FMF Expansion Chambers

Exclusively designed and tested by Flying Machine Factory, expansion chambers are tuned to produce usable horsepower over a broad RPM range. All FMF Expansion Chambers come complete with a glass pack rebuildable silencer and all brackets for bolt-on installation. Pipes come in high or low styles and meet 1976 A.M.A. noise requirements. Introducing the new "Pro" pipe.

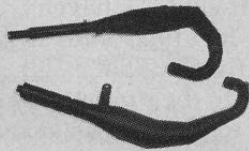

#### Marty Smith Replica Swingarm

This lightweight swingarm allows shocks to be forward mounted for increased rear wheel travel. Constructed from Heli-arc welded 4130 chrome moly, swingarm resists flexing and improves handling. Swingarm uses stock chain adjuster and has all brackets to mount brake anchor arm and chain guide and swingarm bushings. Available for CR 125 \$109.95



#### Heavy Duty Clutch Springs

Springs allow clutch to handle power from hi-performance or modified engines. Eliminates slipping and excess heat build-up in the clutch. Reduces wear in clutch and transmission. Available for CR 125 \$6.95

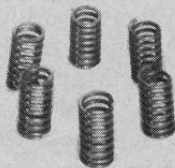

#### Fork Leg Protector

Impact absorbant foam protector fits front of any motocross front fork leg to protect against flying rocks. Supplied with 3 nylon ties for quick installation. \$3.95

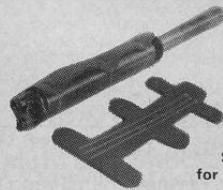

#### NEW 1976 CATALOG

NEW 1976 CATALOG 2.00

- SWINGARM BUSHINGS \$ 10.95
- CR 125 10.95
- CR 250 11.95
- IMR 175 11.95
- IMT 250 56.95
- PORCUPINE CYLINDER HEAD 275.90
- MARTY SMITH REPLICA 39.95
- MARTY SMITH REPLICA ENGINE KIT 240.98
- AIR BOX ASSEMBLY 285.98
- SLEEVE DOWN KIT 14.95
- Standard porting 15.95
- Boost porting 9.95
- AIR OIL SUSPENSION CONVERSION 53.95
- 74 CR 125 57.95
- 74 CR 250 59.95
- 75 CR 125 69.00
- 75 CR 250 74.95
- EXPANSION CHAMBERS 33.95
- 73-75 CR 125 low Standard 109.95
- 73-75 CR 125 low "Pro" 6.95
- 73-75 CR 250 low 3.95
- 75 CR 250 MI high 6.95
- 73-75 XR - 75 low 3.95
- SWINGARM
- HEAVY DUTY CLUTCH SPRINGS
- FORK PROTECTOR

To Order:

Check each FMF product you wish to order. Total prices, add tax where applicable, complete order form, and mail to FMF. Your order will be shipped to you postage C.O.D.

ORDER FORM (total of order)

MAIL TODAY!!!

Enclosed is my  check  money order for \$ \_\_\_\_\_

Name \_\_\_\_\_ Address \_\_\_\_\_ City \_\_\_\_\_ State \_\_\_\_\_ Zip \_\_\_\_\_

Motorcycle Make \_\_\_\_\_ Model \_\_\_\_\_ Year \_\_\_\_\_

\*Please notify me of my appointment date.



Mail to:  
1416 W. 259th St., Dept. MX  
Harbor City, CA 90710

Cal. res. add 6% sales tax  
TOTAL \$ \_\_\_\_\_  
F.O.B. Harbor City, CA

# DIRT

By Holbert Holquist

Kawasaki of Canada's Jan-Eric Sallqvist wrapped up his second consecutive Canadian motocross championship by winning the Open Expert class at Ste. Julie, Quebec in September. Sallqvist, riding his last National series for Kawasaki's Canadian distributor, finished the four race championship series with a one-point margin over Can-Am's American ace, Mike Runyard. Sallqvist amassed 97 points on his way to the Open Expert title, while Runyard won the 250 Expert with 96 points. Canadian championship standings are determined by a rider's highest point total in a single class, regardless of the number of classes he competes in.

I hear that Sallqvist and his tuner Cliff White (see *Whips*) are now looking for a sponsor, since Kawasaki Canada is withdrawing from racing due to business reverses over the past year. Sound familiar?

\* \* \*



\* \* \*

Holbert just got the word that a massive case of bad vibes for the sport was avoided when Pierre Karsmakers decided to drop his protest to the AMA (as well as a rumored civil suit) about the goings-on at the New Orleans National. The whole thing started because Pierre felt that Brad Lackey and Tony DiStefano conspired together against him to help Jimmy Weinert win the race and the championship. Pierre still feels he was done wrong, but he can't prove it. So he's dropped his appeal of the after-race protest he originally made to referee Chuck McCall, which was denied. With motocross out of the courts and back on the tracks, it's going to be an interesting new season. And hot, too.

\* \* \*

What hot young motocrosser is currently leading our ROY Award balloting? Only Holbert knows, hee-hee.

\* \* \*

Boy, have I been hearing grumbles from some of the Trans-AMA fans about advertising all the Europeans that are going to be at certain events and some showing up at the first, only to find that the Suzuki team entry from Europe and Gilbert DeRoover are the only foreign riders. Eight bucks at the gate didn't help things much.

\* \* \*

Speaking about the Trans-AMA, it seems there's a move afoot to cancel the series next year. A bunch of the promoters got with some AMA people and they're thinking it over. What do you think?

\* \* \*

Back in September, Dick Miller, the guy who lets me do this column, got a real, live, bona fide, autographed copy of a works Heikki Mikkola postcard from none other than Heikki Mikkola. It said, "En ole teh — nyt . . ." Oh, don't read Finnish, huh? OK, old Holbert will translate for you (had to do it for Miller, anyway). It said, "I haven't signed a contract for 1976 and all rumors are untrue." That "all rumors" part refers to the rumor that Heikki was going to Honda. That's class, Miller.

\* \* \*

Here's the official schedule for the National Motorcycle League's Florida Winter Nationals, in which every motocross rider in the U.S. is invited to compete. The top twenty finishers in each class (both pro and amateur) will be declared the NML national numbers, and will carry those numbers through 1976.

Jan. 25	
Homosassa Springs, Florida ..	\$2400
Feb. 1	
Cocoa Beach, Florida .....	\$2400
Feb. 8	
Pompano Beach, Florida .....	\$2400
Feb. 15	
Orlando, Florida .....	\$2400
Feb. 22	
Pensacola, Florida .....	\$2400
Feb. 29	
Jacksonville, Florida .....	\$2400

\* \* \*

Suzuki's Billy Grossi was tuning up for the Trans-AMA at a local race near his hometown of Santa Cruz, California, when he fell on a downhill and broke his left leg — opposite from the one he busted last year. So Billy missed the Trans-AMA series, but he says he'll be back in time for the Nationals this year.

\* \* \*

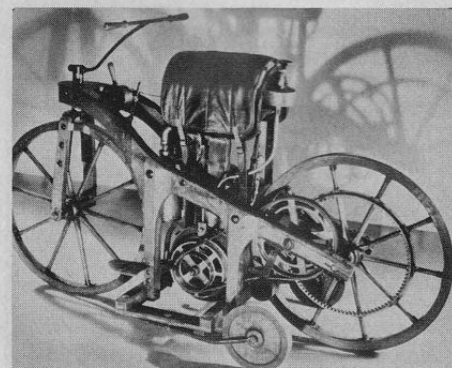

Wondering what this thing is? Nope, it's not a cleaning machine. It's a model of the world's first motorcycle as manufactured by Gottlieb Daimler. No motocross model, this thing had a wooden frame and a 0.5 hp aircooled engine, with two gear ratios which the rider selected by moving the leather drive belt from one pulley to another — with the engine stopped. The bike also had two outrigger wheels for stability, since the streets in the area were constructed of cobblestones. Old Gottlieb later merged his company with that of Karl Benz to produce the Mercedes-Benz car, and went out of the motorcycle business. How about that?

\* \* \*

Holbert's buddy John Fischer sent him a copy of the tech inspection rules at Maplehurst Cycle Park in Illinois. John says that everyone is given a copy of the rules along with their pre-entry forms, and that he feels it's about time. I, Holbert Holquist, agree.

The rules, then: (1) three legible number plates, (2) folding footpegs, (3) snap-back throttle, (4) ball on ends of levers, (5) eight-inch high boots, (6) eye protection, (7) helmet with number, (8) silencers in working condition, (9) all fenders intact, (10) front and rear brakes. Some of those things sound pretty obvious, but people still show up without them. Let's hear it for Maplehurst C.P. III

# ALL NEW PRODUCTS FROM DG



# Book of Tricks for 1975 \$1<sup>00</sup>

ORDER YOURS TODAY!

5552 La Palma Avenue East ■ Anaheim, California 92806 ■ 714/996-4430 #11

## HERE IT IS!

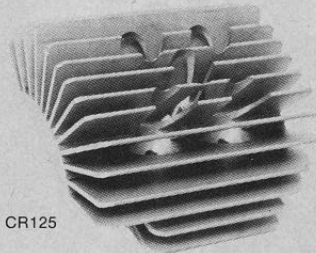

CR125

### DG's 1976 model 17-fin Radial Head

A totally new design concept: new combustion chamber provides more horsepower instantly. Dyno-testing shows the 17-fin design reduces head and exhaust temperatures by as much as 100 degrees. New manufacturing method keeps price low. Available now for CR125 ... **\$39.95** and a new 13-fin model for YZ80 **\$34.95**

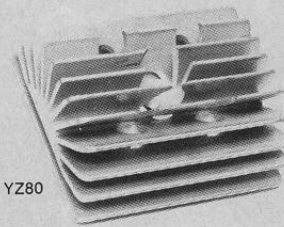

YZ80

### NEW! NEW! NEW! NEW Radial Head for YZC Mono and Suzuki RM125 **\$39.95**

Now available from DG

### The Gas Girling Shock

What makes the Gas Girling so great? Just ask Heikki Mikkola—they're the ones he won with. Available in 11.8 or 13-inch; specify 80, 90, 100, 110-lb. spring rate (springs included) ... **\$98.50/pr.**



Now you have a choice ... Aluminum or Chromoly.

### DG ALUMINUM SWING ARMS

The famous DG swing arm in either the forward-mount or lay-down design is now manufactured from weight-saving aluminum at no increase in price. (**\$109.95 most models.**) Available for Honda, Suzuki, Kawasaki, Yamaha (soon available for others.)

LAY-DOWN FORWARD-MOUNT

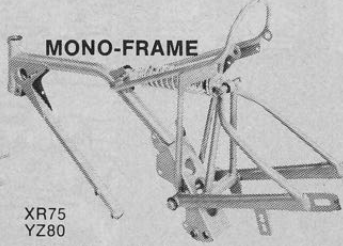
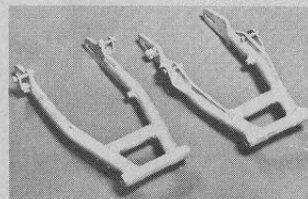

MONO-FRAME

XR75 YZ80

DG's Mono-shock frame uses 4130 chromoly with gold-anodized cadmium plating. Heliarc welded for max. strength. Won't scratch, chip or peel. Stock components fit. Frame only

XR75 .....	<b>\$295.00</b>
YZ80 .....	<b>\$325.00</b>
with Gas Bilstein shock	
XR .....	<b>\$349.00</b>
YZ .....	<b>\$379.00</b>

### \*SOON AVAILABLE\* CR MONO-FRAME



### 125YZC (Mono) PIPE

Dave Williams won the Mammoth Mountain Motocross with this pipe ... **\$48.95**

Suzuki RM125 Pipe ..... **\$48.95**



Available from DG

### The New Inter-Am Solid-Stock Aluminum Handlebars AMA-approved

The super-light, super-strong, SUPER BAR by Inter-Am. Made from #2024 solid-stock anodized aluminum, with almost twice the bending resistance of chromoly and almost 4 times that of mild steel. And, no more cross bar to loosen your teeth. Available in beautiful anodized Silver, Gold, or Black ... **\$14.95**

### We also have the Marzocchi Gas Shock in all popular links and valving. **\$99.50 complete.**



### FORK BOOTS **\$8.95/pr.**

High quality rubber; accordian design. Protect front fork works. Black, also in red, yellow, or blue.

### Sprocket Kit with Chain

Eliminate chain problems on your CR125. Uses 520 chain. Countershaft drilled and tapped. Horseshoe-clip included. Rear teeth: 48, 49, 50 or 51. Front teeth: 12, 13 or 14. ... **\$42.95**

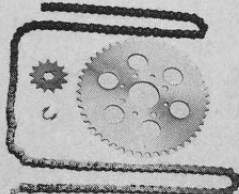

### SHOULDER & CHEST PROTECTOR by KOHO

Complete freedom of movement with maximum protection. Shoulder caps and biceps of white, shock-resistant polyethylene. Chest and back of poly reinforced foam. Covered with yellow, moisture-proof Nyltex nylon. Fully adjustable Velcro straps—comfortable, form-fitting without bulk. Very lightweight ... **\$39.95**

### Heavy Duty Clutch Springs

For CR125. Adds to clutch life, stops power loss due to slippage. Set of 6 ... **\$6.95**

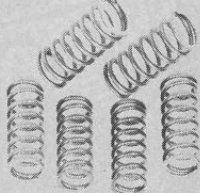

### GAS YOUR FORKS!

Adaptor for charging front fork with air for extra cushion. Lets you remove fork springs and run with a straight air/oil suspension. Yamaha, Suzuki, and Honda (others soon) ... **\$15.95/pr.**

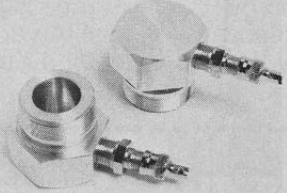

### JT Racing "Phase II" FOAM AIR FILTER

Available for most models of racing bikes. Prices vary.



**\$23.95**

### DG SKATEBOARD

Manufactured from unbreakable urethane with anti-slip surface. Has that just-right flex and an extra wide tail for better footing. The trucks are specifically designed for skate boards. Urethane board has 100% guarantee against breakage. Available in red, yellow or blue.

DG is proud to offer

### TIBBLIN GLOVES

Superior quality. Manufacturer guarantees materials and workmanship for 3 months. 100% lambskin, fully padded. S, M, L, XL. ... **\$28.85/pr.**

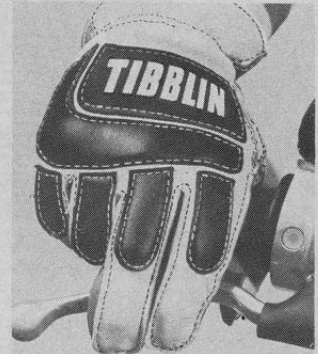

### Fin Fighter "707" FACE MASK

Developed by JT Racing, Heikki Mikkola, and KOHO of Finland, new design features venting to provide more "breathable" air and cooler circulation of air; adjustable to wear close in, far out, tilted; shatterproof, bends but doesn't break. Streamlined look in red, white and blue Mikkola colors ... **\$8.95**



### MIKKOLA "UNLEATHERS" by KOHO AMA-approved

These are the new GP pants that the Moto-X world is raving about. Made of nylon and goat skin, they combine the best features of both. Lightweight ... cool ... water-repellent ... durable. Ideal for desert or back east hot, humid summer riding. Goat skin in crotch and inner knee helps you keep a grip on your machine. Available in Mikkola red, white and blue; Team Yamaha white-yellow and black; Team Husky blue with yellow strip; Team Maico red-black and yellow ... **\$110.95**

DEALER INQUIRY INVITED

# We're blowing the doors off racing.

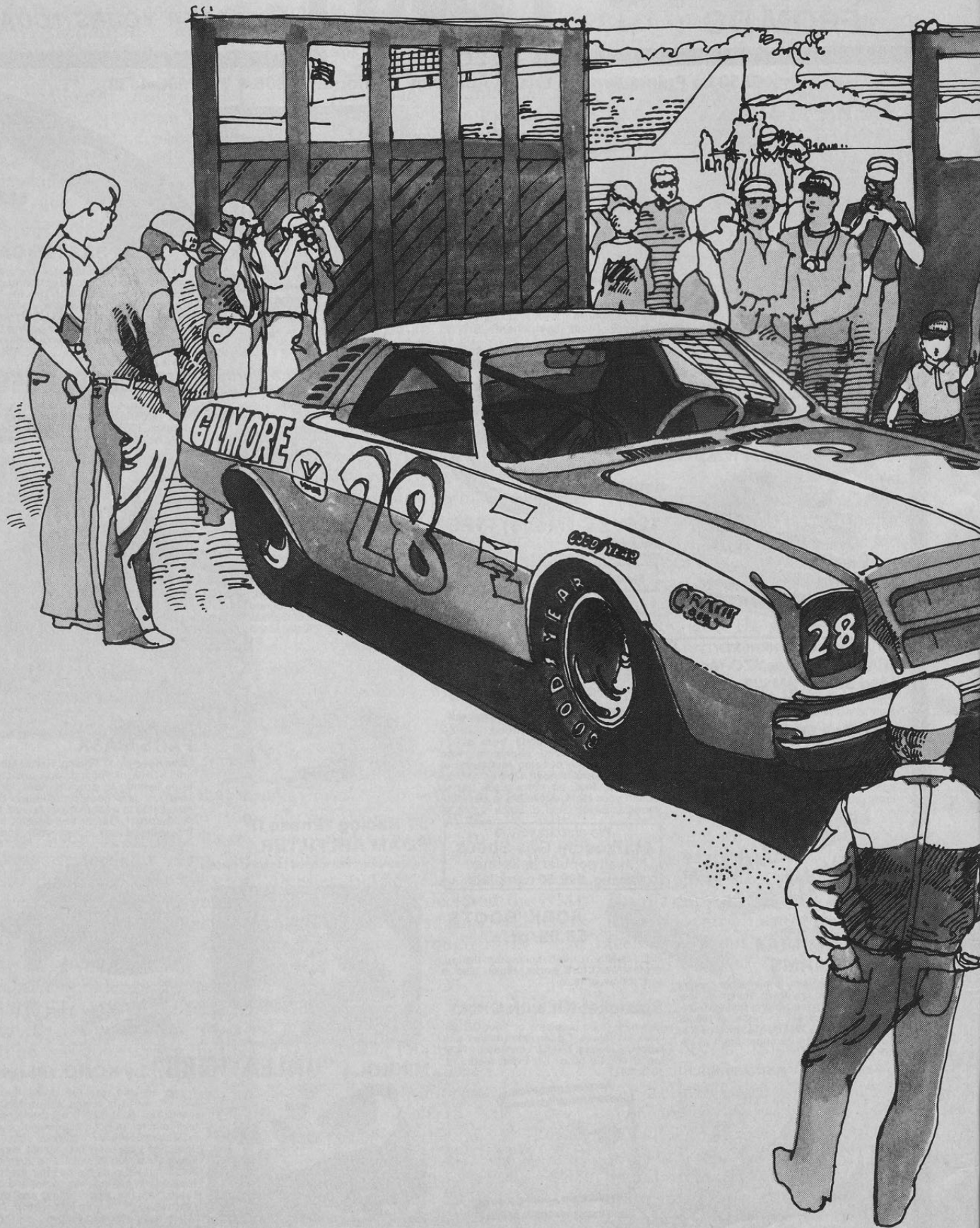

# Get closer to racing. Join Goodyear's Motor Sports Club.



We know you want to get closer to racing. We also know how hard it is to get through the doors and gates between you and the cars and drivers. Not any more. That's what the Goodyear Motor Sports Club is all about, getting you closer to racing. And here's how:

- We'll host you in reserved hospitality areas, close to the action at all kinds of racing events across the country.
- We arrange tours of garage areas, where you'll get a chance to talk to guys who build and crew cars.
  - Drivers will take the time to be with the club and answer questions, sign autographs, even bench race.
- What drivers? How's this for an Advisory Board: A. J. Foyt, Richard Petty, Jackie Stewart, Bobby Unser, Don (Big Daddy) Garlits, Dan Gurney, Johnny Rutherford, Graham Hill, Roger Penske, and Kenny Roberts. Not bad? We've just added Mario Andretti, Brian Redman, Cale Yarborough, David Pearson, Peter Gregg and Bobby Allison.
- Special drawings are held with

members winning things like steering wheels from cars that have won major races. Auto-graphed checkered flags. Or special privileges—one female member actually kissed Bobby Unser at the Indy 500 victory celebration.

- You'll get freebies and worthwhile discounts on things like tickets and club merchandise.
- We'll send you CHALLENGE, a quarterly magazine covering all kinds of racing, from Daytona to Ontario to Watkins Glen. Plus a monthly newsletter crammed with club news, race schedules and upcoming activities.
- Naturally, there are things you expect from a club—an embroidered jacket patch, decals, bumper sticker, cap, membership certificate, and a membership card that's your admission pass to the many scheduled club events.

That's what we're all about: opening doors and getting you closer to the people and manufacturers who are racing.

So come on down from the grandstands and join us. Won't you?

<b>Membership application.</b> Please enroll me as a member of the Goodyear Motor Sports Club and rush my complete membership kit.		<b>FULL 12-MONTH MEMBERSHIP \$15.00</b>	Annual associate memberships available to immediate family of Full Member only. \$5.00 (First person) \$3.00 (Each add'l person)
Please check method of payment: <input type="checkbox"/> Check or money order—payable to Goodyear Motor Sports Club		Insert payment in envelope with this application. Mail to Goodyear Motor Sports Club, P.O. Box 66, Akron, Ohio 44316.	
<input type="checkbox"/> Master Charge <input type="checkbox"/> BankAmericard <input type="checkbox"/> American Express <input type="checkbox"/> Send Information Kit			
Please charge to my credit card account.	(Please print) Full member	Family member(s). Immediate family only.	
Credit Card No.	Name	Name	Relationship
Expiration Date	Address	Address	
	City	City	
Interbank No. (Master Charge only) Located above your name.	State	State	Zip
	Zip	Cap size. Please check one.	
	<input type="checkbox"/> Small/Medium <input type="checkbox"/> Large/Extra Large	<input type="checkbox"/> Small/Medium <input type="checkbox"/> Large/Extra Large	
Signature			
For additional family members, print name, etc., on blank paper and insert in envelope with this application. Be sure to calculate correct fee. Mail to Goodyear Motor Sports Club, P.O. Box 66, Akron, Ohio 44316.			

**GOODYEAR**  
Motor Sports Club

# WRENCH WRACING

By ARDIMOS MIERSTEDT

## CR250 GEARBOX E-Z FIX

Dear WW readers:

You say you're gonna end it all 'cause your CR250 just ate its 19th consecutive gearbox? A new tranny won't even last to the starting line?? Is that what's bothering you, eh boobie? Well, it could be the Kamikaze shift drum pawl pin has died a glorious death and took your shift drum with it. If it's not too late already, whip in a 24261-357-010 from an MT250, which is a far more honorable unit. For a buck and a half, it's cheap insurance. If only Pierre had known . . .

Mable Leaf  
Outrage, Canada

*But Mable, what mean-um 24261-357-010?*

## STRANGE NOISES

Dear Ardimos:

My engine is making a strange sound? What could it be?

Ronald McDougal  
Buena Park, California

*Many things, Ronald, many things. Listening to an engine make noise is like listening to somebody in the bathroom; you can always tell what's going on by the sounds. The clinking and jabbering of an engine are its way of telling you how it feels. If your piston is getting loose, it rattles like a nickel in a mayonnaise jar. Worn pins will give a steady klink. A loose spark plug can make a distinct mechanical klack when the pressures of ignition escape through the threads. Your engine talks to you with its exhaust note. It can tell you when its mixture is wrong or when its points have run themselves out of adjustment. But when your engine is really sick, it gives you the most disturbing sound of all: Silence.*

## THE ULTIMATE LAYDOWN

Dear MXA:

I have been experimenting with laid-down shocks and after much thought I've decided to move the shocks on my 250 Maico to a horizontal position, the ultimate laydown.

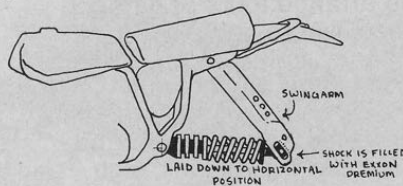

I also reworked my forks after reading about the pros using gas-filled forks. I removed the springs and filled the fork tubes to the brim with Exxon Extra. Now I can't decide whether the front works better than the back or the back works better than the front.

Jose Tavish  
Roanoke, Virginia

*Your rear suspension setup looks like it would be great for backing into walls.*

## BULTACO WARRANTY

Dear Ardimos:

Would you please explain to me the Bultaco warranty? Every time I try to get it from my dealer he has a different explanation.

John Wilson  
Portland, Oregon

*I could, but I think Bill Haas of the Bultaco Service Department in Virginia Beach can do it better. Take it, Bill:*

*Many warranties are being received that have to be disallowed for various reasons. The items listed below should help to clear up some of the problem areas.*

1. Warranty claims must be run through the imprinter, using the customer warranty identification card. All customers have their card within ten days of mailing the registration to Bultaco International Ltd. Incomplete claims will not be considered, such as improper or omitted part numbers, description of defect and claims not being legible.

2. Parts that fail for reasons of abuse or collision will not be considered.

3. Parts that have been modified in any manner will not be considered for warranty.

4. Parts that are considered maintenance items (spark plugs, points, cables, final drive chains, tires, tubes, oil, etc.) will not be considered for warranty.

5. Heckel boots are warrantied for one year against manufacturing defects only. No warranty consideration will be given to boots for normal wear and abuse. Boot claims must be completed with part numbers, customer name, date of sale and description of the defect.

6. Parts and claims must be received in Virginia Beach within 30 days of the repair date or will not be considered for warranty.

*Our warranty policy this year is quite liberal when you consider that it covers raced motorcycles. It is probably the most liberal policy in the industry; therefore implementation of a warranty of this nature requires the dealer to use his judgment concerning failures.*

*It is impossible to strictly define the words abuse, misuse and negligence as used in this warranty. I will therefore try to give several examples of each to help you with your decisions.*

*Webster defines abuse as "improper use or treatment"; he defines misuse as "using incorrectly, abusing or mistreating"; and he defines negligence as "the failure to exercise the care that a prudent person exercises." For example, bent front rims resulting from collisions with trees, rocks, etc., would be abuse; a broken frame on a Sherpa T used at a motocross is misuse; deteriorating chrome paint or rubber on a motorcycle being left outside in the rain and other elements would be a result of negligence; however, on the other side of the coin, a rim that is cracked at the seam and not dented from a collision would be a manufacturing defect. A broken*

MOTOCROSS

frame on a Pursang used in motocross events again would be a defect because the motorcycle was not misused. Defective tanks that are leaking or have crazed gel coats were not caused by negligence and therefore would be a manufacturing defect. An item that is not specifically mentioned but one that must come into account is alterations; by that I mean any happy speed tuner that has raised his exhaust port 3mm deserves the broken connecting rod and various broken pieces that go along with running his Astro at 15,000 rpm.

Abuse, misuse and negligence, also alterations, are all closely related and to a great degree must be decided at the dealer level. Rods that fail when the motorcycle is run under water and the cylinder is filled with water is definitely not a manufacturing defect. We intend to cover units that fail because of defects in manufacture. It is normally quite evident when a motorcycle or parts of a motorcycle have been abused or misused.

In closing I can sum it up by saying that we intend to warranty items that are defective in manufacture, not items that have failed because of defects in intelligence.

William Haas  
Bultaco Service Department

#### WHAT MEAN 'UM ARDIMOS

Dear MXA:

Who the hell is Ardimos Mierstedt?

Michael Koroly  
Bronx, New York

*He ain't Gordon Jennings.*

#### TM HOP-UP

Dear Mr. Mierstedt:

I'm writing this letter in response to Kent Annolone. I also own a stock Suzuki TM125 and I kinda did my own porting job. I took a two millimeter spacer and put it under the cylinder and ground down on the exhaust side of my piston half the distance between the rings. Then I took a little off the intake and then

two millimeters off the cylinder head and put it back together. I went to Orlando for practice and beat a Yamaha 250 MX in a drag race.

Kenny Hubbard  
New Smyrna, Florida

*My grandmother can beat a 250 MX with her wheelchair. Besides, with 2mm off the head you probably could've beaten a 450 Maico till your motor blew.*

#### SLIPSTREAMING

Dear Sir:

I would like to know if it is

possible to jet stream in motocross like in car racing.

Douglas Shannon  
Sunnyside, Washington

*Slipstreaming, or "drafting," as it is more commonly known, works for car racers, motorcycle road racers and bicycle racers, but I don't think it works for motocrossers. Any advantage gained by drafting in motocross would be so slight as to be insignificant. The tracks are too bumpy and the speeds aren't high enough.*

**IMPOSSIBLE!**

A 125cc bike cannot beat 250s in a long race, on an open track. Right? Wrong!

Bobby Jones zapped the country's top 250 riders when he took the 125cc class at SCORE's Off-Road World Championships at Riverside, Calif.

**PK Racing Products make the impossible happen**

FOR THE RECORD: In his first major motorcycle race, former mini champ Bobby Jones averaged 51.09 mph over the 3.5-mile Riverside course. on his PK-Hacienda Honda Elsinore 125. Honda factory rider Steve Holladay won the 250cc class averaging 50.9 mph. 'Nuff said?

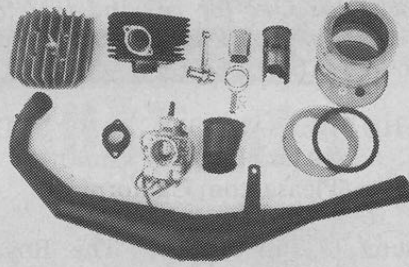

(Top, l-r) CR-125 hi-comp. radial-fin head, runs cool (also MR-50 & YZ-80); CR-125 cylinder porting, Phases 1 thru 4, \$50 to \$99; SL-100 polished con rod kit, includes crank pin & lower bearing; CR 100cc kit, includes piston, rings, pin and sleeve; Hi-volume foam air-cleaner CR kit; (Center) Hi-volume intake manifold; 30mm Mikuni carb; Hi-volume filter-Mikuni connector boot; (Bottom) PK pipe (stormer).

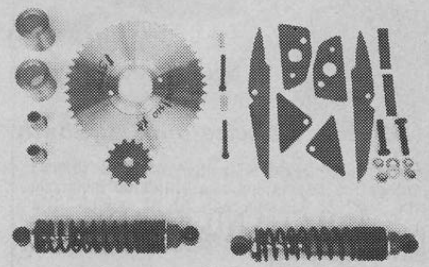

Suspension & other stuff (Top, l-r) Boge shocker coolers, (spec. model); Bronze swing arm bushings; End chain breakage with 520 chain kit, alloy rear sprocket (46, 48, 50 & 52T) and countershaft sprocket (12, 13 & 14T); CR-125-250 frt. fork travel extender, gives 8" travel; CR-125-250 kit for forward mounting of shocks on swing arm; (Bottom) Boge shocks, rebuildable, 10.75", 11.75" or 13".

I'd like to achieve the impossible, send me: CR-125 radial head  \$39.95; MR-50  or YZ-80  radial head, \$29.95; SL-100 polished con rod kit  \$18.95; CR-100 kit  \$79.95; CR air cleaner  \$11.95; CR intake manifold  \$6.95; 30mm Mikuni carb  \$35.95; Connector boot  \$6.95; PK pipe  \$49.95; Shock coolers  \$7.95; Swing arm bushings  \$11.95; 520 chain kit  \$24.95; Fork travel extender  \$7.95; Forward shock mount kit  \$19.95; Boge shocks [spec. length]  \$54.95.

Check or M/O for \$..... enclosed. Specs & prices subject to change.

Name: ..... Street: .....

City: ..... State: ..... Zip: .....

**HACIENDA HONDA, distributor for PK Racing Products,**  
507 North Azusa Ave., La Puente, Calif. 91744 (213) 968-6461

MX-1

The world's BEST motocross cycle!

**MAICO**

See your local dealer or write for free literature including latest road tests.

Cooper Motors, 110 E. Santa Anita Ave., Burbank, CA 91502  
Maico Motorcycles Inc., 109 Electric Av., Lewistown, PA 17044

# MAIL ENTRIES



"WHAT MEAN 'UM WFO?"

## SOME DAYS . . .

Dear MXA people:

A few weeks ago, while attending a night MX at Bee Line MX track, I was mixed up in an accident involving the side of my car and a seven-year-old kid on a mini bike. At the time, the kid was racing in the spectator parking lot. When all the dust cleared, the kid ended up with a cut on his leg and I ended up getting punched out by his over-reacting dad. My question is: Does "Hi-Torque" Publications have anything to do with AJS powerbands?

The DNF Kid  
Scottsdale, Arizona

*(No, but we seize once a month. —ed.)*

## WHAT A NICE LADY

Dear Sirs:

I sometimes pick up one of your magazines from a stack that my son has. I must say that your colored photos are very beautiful. My son, who is 15, has a Suzuki 125 or however you call it. He's so much of a cycle fanatic, including reading magazines, etc., that I have to admire him. I don't know a thing about bikes, and once when my boy was naming all the bikes he said "Montesa," so I asked if there was one called "Montego." I'm really writing to you because I'm a wrestling fan and I love the sport as much as Tommy loves dirt bikes, etc. I only wish those wrestling mags

would have beautiful colored shots like you do.

Lori Strickland  
Hawaii

*(How about a nice shot of Haystacks Calhoun bodyslamming a KX450? —ed.)*

## TEAM POLISH MOTOCROSS ACTION:

I would like to know if us Polacks have a motocross team. Also, for riding desert, I was thinking of a Husky 250 WR or their 250 GP, but after reading your test on the Can-Am 250 MX2 I really got to like the Can-Am. But I also read that the Yamaha YZ250B is a good bike. I had my heart set on a Husky but now I am really mixed up.

Chris Grochowski  
Tucson, Arizona

*(Don't forget the CZ and the Maico. And what about the Bultaco, Ossa and Montesa? They're all good bikes. The Suzuki is excellent this year and the Kawasaki puts out good power. And have you looked into the Penton? BSA maybe? You could wait for the Harley 250MX to come out. There's always the Honda. What do you think now? —ed.) (It's against editorial policy of this magazine to encourage ethnic jokes, but didja hear the one about the Polish motocrosser who had to make three pit stops? One for gas and two for directions! HAH HAH HAH HAH HAH HAH HAAAAAA! —ass. ed.)*

## THE PLEASANTON GRAND PRIX by Mark (Smokin') Smith Pleasanton, California

(sung to the tune of "The Royal Crown Cola Song")

Well, I pulled into the cycle park,  
At five-forty-three.

I walked over to the sign-up booth  
Of the Pleasanton Grand Prix.

After getting things all squared  
away,  
I put on my MX stuff.  
I strapped on my new rock guard  
'Cause I knew the track was rough.

When I wheeled my machine out  
of the van —

*(Wait a minute! Wait a minute! I*

*never heard of "The Royal Crown Cola Song." —ed.)*

## BIMBO WAS A FLATTRACKIN' MAN

Dear Sir:

Do you know Jim Pomeroy used to race flattrack?

Douglas Shannon  
Sunnyside, Washington

*(No, but if you'll hum a few bars . . . —ed.) (Does it go anything like "The Royal Crown Cola Song"? — ass. ed.)*

## WHAT DOES IT MEAN'UM Dear MXA:

How come you guys never really answer the letters about what does WFO mean? Is it because you don't know yourself?

Brian Glass  
Redondo Beach, California

*(No, it's because we don't like to answer stupid questions. —ed.)*

## PETER STARR

Dear MXA:

Did ya see the special about Roger D.? If you didn't you really missed something. Congrats to Peter Starr.

Kirk Douglas  
Poplar Bluff, Missouri

## To MOTOCROSS ACTION:

Tell me all you can about getting the Peter Starr film of Roger DeCoster for my motorcycle club or our local TV studio.

Joe Reed  
Shreveport, Louisiana

*(Easy. Just write Peter Starr, c/o this magazine. —ed.)*

Dear Folks:

Read about your genuine filmmaker Peter Starr's new motocross movies and would like to see about getting them shown in Virginia.

John Schons  
Radford, Virginia

*(Talk to Joe Reed. —ed.)*

## MORE PIPES

Dear MXA, Baz, etc.:

I thought that guy from Arizona who made the "pipe" out of the carburetor had a good idea. I hooked up an old fish tank pump to one of my water pipes. All you do is fit a cork in the top of the bowl and

run the hose into it. It makes the smoke super-cool and gives great "shotguns."

Rich Hanley  
Baldwin, New York

(What are you talking about? —ed.) (C'mere, Miller, I want to show you something. —ass. ed.)

### MXA IMMORTALIZED

Hey Baz:

I read your bitchin' Maico test and was moved to paint your words on my trailer.

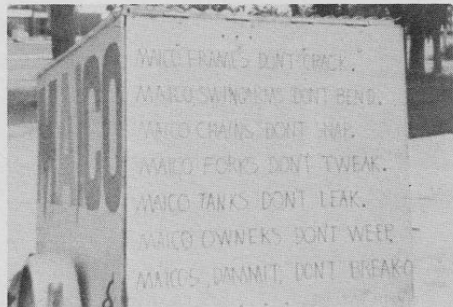

I'll get the words on better a little later. Notice the empty can on the fender? Maicos go so fast and ride so nice we have to break training to give the competition a chance.

Brad Stoddard  
Delta, Utah

### BOSS GLOVES

Dear MXA:

I am writing in regard to Dick Miller's article in your August issue. I want you to know that I too believe that 35-percent tax is too much. As for the Federal Government, well,

why they don't want to be fair about this we may never know.

Brian Cowell  
Fort Bragg, California

(You've got a point there, Brian. —ed.)

### FREE STICKIES

Dear Sir, Maam, or whatever:

I am 12 years old and 12-year-old kids aren't exactly rich. So could you please send me some stickers you might have lying around down there?

Melvyn Smyth  
Venice, California

(Are you trying to say we keep a messy office? —ed.)

### MORE MISQUES

Dear MX ACTION:

I was reading through your October mag and found a mistake on page 41. The captions do not match up with the camera clickery.

TM Smolik  
Upper Darby, Pennsylvania

Dear MXA:

If the captions and photos on page 41 of the October issue go together, I'll eat the foam air cleaner off my DT3 (after 5000 miles) and give out trophies and kisses at the USGP.

Fred "DT" Hine  
Cincinnati, Ohio

(May the gas tank bolts of a thousand early Huskys find their way to your goodies. —ed.)



Pewter Buckles (with solid brass hooks to insure maximum durability and guaranteed not to break off). Curved to fit the contour of your waist.

Any Pewter Buckle \$4.00

3/\$10.00

Specify Either Antique Solid Pewter (Silver) or Antique Brass Finish (Gold)

Genuine leather belts (black or brown) \$5.00  
1 3/4" width, oil tanned & waxed (sizes 26-46)

Add 50c for postage & handling for each item ordered.

Color Catalogue of over 250 Styles \$1.00

ALL BUCKLES FIT ANY 1 1/2" to 2" BELT  
Also Available Special Club and Organizational Buckles; Send for Details

Send To: Alliance American Antique Corp.  
P.O. Box 713, Dept. MX-1, Midtown Sta., N.Y., N.Y. 10016

— Money Back Guarantee —  
N.Y. Residents Add 7% Sales Tax. MX-1

Enclosed \$  Check  M.O. Model # \_\_\_\_\_  
Name \_\_\_\_\_  
Address \_\_\_\_\_  
City \_\_\_\_\_ State \_\_\_\_\_ Zip \_\_\_\_\_  
 Master Charge  Diners  American Exp.  
Interbank # \_\_\_\_\_ Card # \_\_\_\_\_  
Signature \_\_\_\_\_ Exp. Date \_\_\_\_\_

## SUPER CDI SYSTEM

for XR-75s,  
YZ-80s, MR-50s  
& CR-125s

# JUST \$175

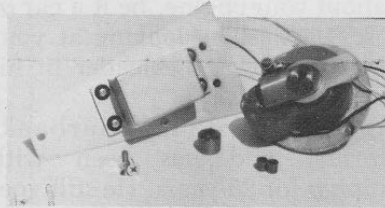

IT'S NEW!  
IT'S LESS EXPENSIVE!  
IT'S BETTER!  
AND IT'S HERE!

Manufactured by Speed'n Sport and distributed by J & H, this capacitor discharge ignition system produces constant voltage at high or low rpm, eliminating starting problems and most spark plug fouling. Breaker points are not used so this constant trouble-source is removed. The system cannot get

out of time since the timing is permanently pre-set. Faster acceleration comes from eliminating the flywheel.

Speed'n Sport CDI systems are shipped complete with coil, spark plug cover, mounting hardware and full instructions.

# J & H

RACING EQUIPMENT

Rush your CDI system. Check or Money order for \$175.00 enclosed.

Dept. MX-1

Name \_\_\_\_\_

Address \_\_\_\_\_

City \_\_\_\_\_

State \_\_\_\_\_

Zip \_\_\_\_\_

P.O. Box 686, Norco, CA 91760 (714) 734-2724

# WHIPS

**Little things about people who make motocross neat**

JEFF BURTT

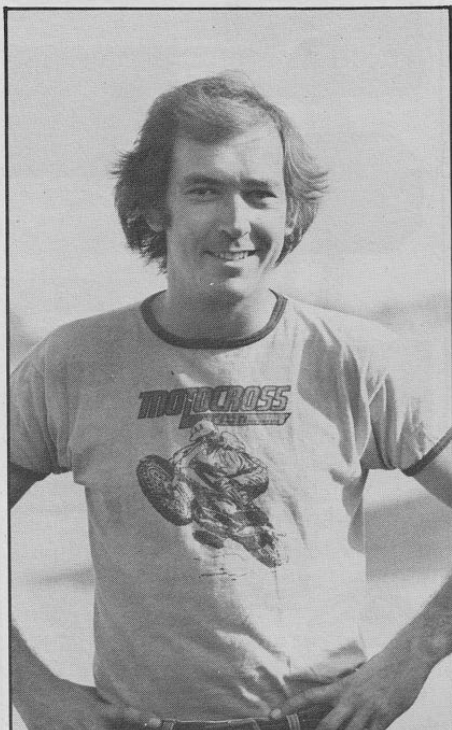

U.S. Suzuki's PR Supervisor likes wearing his MXA T-shirt around, much to the chagrin of some of the other moto monthlies. We thought it showed so much class we made him a Whip. Jeff is 29, unmarried and has been with Suzuki for about a year and a half.

He said he actually didn't get into bikes until a few years back because he was really hooked on surfing, which took up a lot of his time. When he finally did start riding, he raced a few MX events and is now rated an Amateur, although he says it should read "low-level amateur."

Working for U.S. Suzuki came as a result of the persistent badgering of Rom Lovil, the head of Public Relations, who he met at UCLA's Graduate School of Journalism. Rom hounded him for a few months until he decided to go for it. Jeff said that at the time he looked like the "Buzzer" used to look, read that "laid back," and that this was a big adjustment for him.

Jeff is, by our standards, a neat guy to work with and does Suzuki proud. We like calling him a friend!

BOBBY STRAHLMANN  
AND  
ARNOLD FRANK

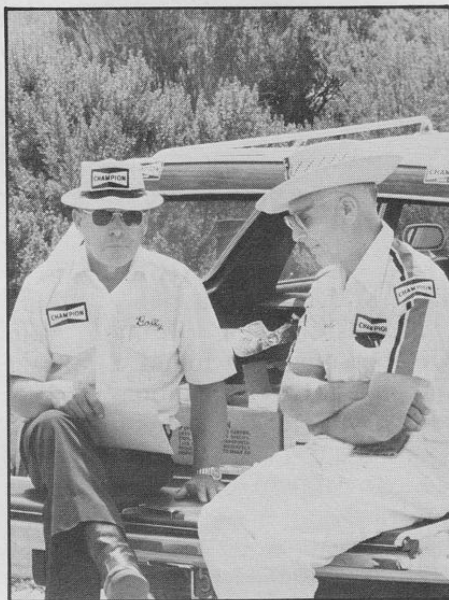

Underneath those two hats with the Champion Spark Plug logos are a combined total of 42 years of spark plug technological experience. If these guys can't help you, then you're in deep . . . trouble.

Bobby is the Racing Manager for Champion and resides in Florida. He used to make all the top motorcycle races in the country but now is seen mostly in the midwest and eastern parts of the U.S. You would be amazed at what he can tell you about your engine, be it a car or motorcycle, just by looking at your spark plug. He is *the* leader in his field.

Arnold lives in Burbank, California, and has been with Champion for 25 years. He still goes out trailing on his bike when he can find the time, and that isn't often. Never without a smile, Arnold averages about 15 motorcycle events a year now, including the car/bike off-road events. When the first MX bikes hit these shores, Arnold was waiting with plugs in hand. Since that time most of the other companies have been playing "catch-up." It couldn't happen to two nicer guys.

CLIFF WHITE



Cliff has probably been the single most important American involved in Canadian motocross over the past couple of seasons. As transplanted Swede Jan-Eric Sallqvist's mechanic, Cliff wrenched as Jan-Eric rode to the Canadian Championships in 1974 and 1975. With Cliff handling the mechanical end, Sallqvist's Kawasakis were bulletproof. He recorded only one DNF in 1975, and that was in a non-points-paying event.

Cliff's greatest mechanical triumph came at the 1975 Canadian Grand Prix, where the put-together "Kawavarna" he concocted out of stock Kawasaki and Husqvarna parts finished sixth against the most sophisticated factory equipment in the world. The "Kawavarna" was one of only ten bikes to finish both motos, and the only non-factory machine to turn the trick.

You can always tell a Cliff White motorcycle by the amount of safety wire it has on it. If Cliff were to stop wrenching, at least two wire manufacturers would have to go out of business. But that's not likely, and the only real question in Cliff's career is whether he'll continue to ply his trade in Canada or move back home to Calabasas, California, where the sun is warmer and the *Supertramp* albums are cheaper. ▮

**M****OFFICIAL VOTING BALLOT**

# 1976 ROY AWARD

## 2nd ANNUAL RIDER OF THE YEAR READER POLL



There are three World Champions. There are as many National Champions. There are all sorts of regional champions, European champions, and untold numbers of local heroes. The AMA has a Number One, the FIM has a Number One, even the town of Climax, Colorado, has a Number One. Now *you*, the esteemed readers of **MOTOCROSS ACTION** Magazine, can once again choose *your* Number One.

All the world's top motocross riders are in a race where your vote will determine the outcome of who is the **KING OF MOTOCROSS**. All riders are eligible to win and all readers are eligible to vote. You may use the official voting ballot or, if you don't want to mess up the magazine, you may make one up yourself. You may vote more than once, but only one vote is allowed per card or letter. **THIS IS YOUR CHANCE TO CHOOSE THE GREATEST MOTOCROSSER; DON'T LET YOUR RIDER DOWN. VOTE!**

**OFFICIAL  
VOTING BALLOT****MOTOCROSS**  
**ACTION** MAGAZINE

## RIDER OF THE YEAR

Fill in the name of your choice for the **MOTOCROSS ACTION RIDER OF THE YEAR** and mail it to:

MOTOCROSS ACTION Magazine  
**RIDER OF THE YEAR**  
 P.O. Box 317  
 Encino, California 91316

Dear **MOTOCROSS ACTION**:

Hi! How ya doin'? I, being a bona fide reader of the magazine, hereby cast my vote for:

\_\_\_\_\_

as **RIDER OF THE YEAR** because I believe he is the greatest motocrosser in the **UNIVERSE**.

# TRICKS FROM THE TRADE



## MX PISTONS

Wiseco now has what they call the "FMX" forged piston for most popular two-stroke dirt bikes. They're available in .020, .040, .060 and .080 oversizes plus standard, and you can get them with a single "L" ring or regular double-ring setup. Wiseco Piston, Inc., Dept. MXA, 7201 Industrial Park Blvd., Mentor, Ohio 44060, will send you a free brochure and the name of your nearest Wiseco dealer.

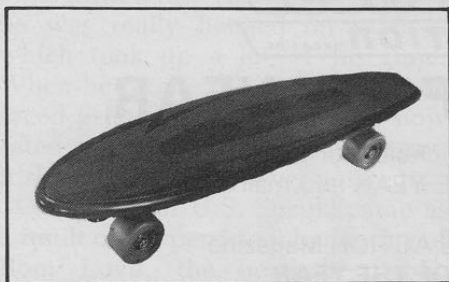

## PRACTICE BOARDS

Practice your moves on a skateboard so you don't thrash your bike. DG sells this ordinary looking board for \$23.95. Look in *Surfer* magazine for some *really* trick boards. DG is at 5552 E. La Palma Ave., Dept. MXA, Anaheim, California 92806; (714) 996-4430. Roy "Tuner" Turner is probably the hottest skateboarder in the AMA, but Peggy Oki can blow his wheels off.

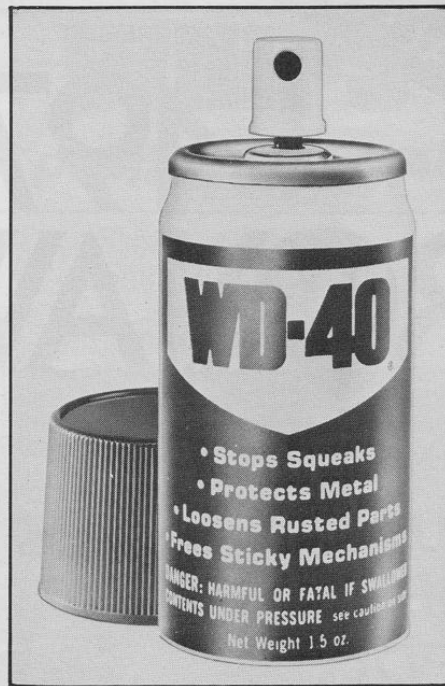

## FREE FREE FREE

Good ol' WD-40. They'll send you a free 1.5-ounce can of the stuff so you can try it. Nice for the toolbox. Send 25 cents in coin to cover postage and handling to: WD-40 Company, Dept. MXA, 1061 Cudahy Place, San Diego, California 92110.

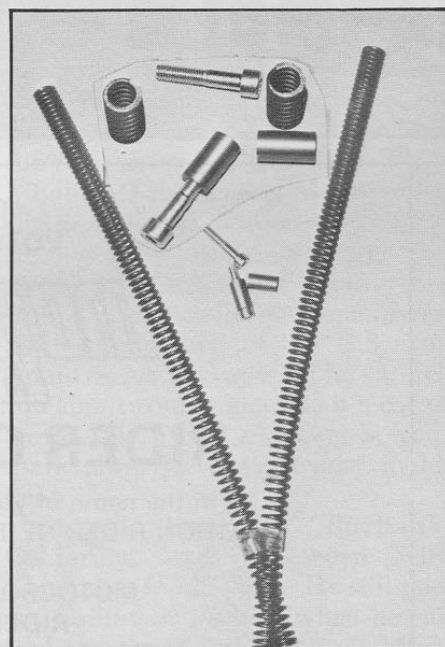

## CR125 FORK KITS

CPW offers two kits for the CR125. Fork Kit "A" is a set of extensions and booster springs. Kit "B" is the extensions and full-length springs. Both kits are supposed to give eight inches of travel. "A" is \$6.99 and "B" is \$16.99. Cycle Products West, 11900 W. Pico Blvd., W. Los Angeles, California 90064; (213) 477-0997.



## NEW CHAINS

Very boss chains are being manufactured by the Whitney Chain Division, Jeffrey Manufacturing Co., Dept. MXA, 237 Hamilton St., Hartford, Connecticut 06102. The Buzzer was born in Hartford so they can't be too bad. Call (203) 527-8261 and ask for the Chain Gang.



## BRAND PADS

Cross-brace pads with Bultaco, Honda, Suzuki or Yamaha logos on them. Ten-inch pad is \$2.24 and 12-inch pad is \$2.95. Get 'em from CYC Distributing Co., Dept. MXA, P.O. Box 467, Hawthorne, California 90250.

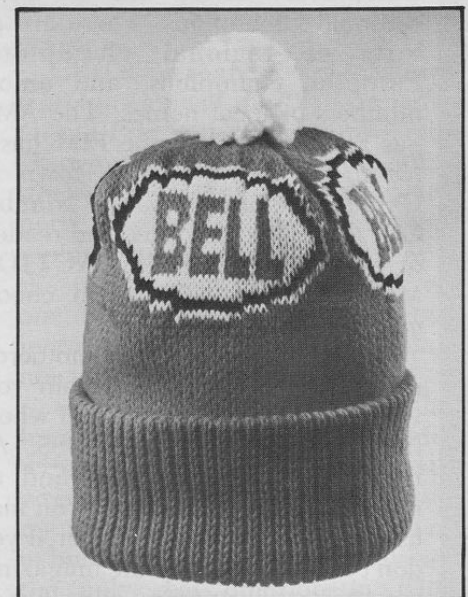

## SOFT HELMET

The Bell Soft Hat may not protect your head like their Super Magnum, but it'll sure keep your ears warm. It's red, of course, and you can get one wherever they sell Bell helmets.

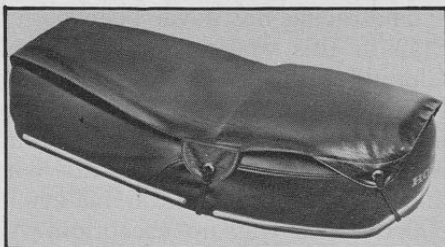

### WATER SEAT

How neat! A waterbed for your street bike. If you've ever slept on a waterbed, you know how comfortable a bag of H<sub>2</sub>O can be. Make sure you put antifreeze in it in the winter. \$24.95 postpaid from D'greens', Dept. MXA, P.O. Box 17135, Tucson, Arizona 85731. Satisfaction guaranteed or your money back.

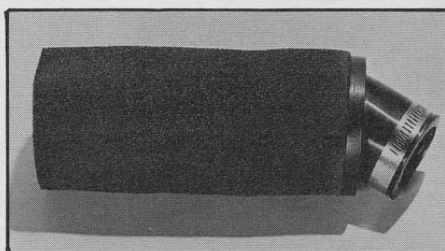

### STRAIGHT THROUGH FILTER

For people who don't like air boxes. It's a filter attached to a hose and clamp. Just what you're looking for. \$7.95 for this XR75 model. J&H, Dept. MXA, 1405 4th St., Norco, California; (714) 734-2724.



### HAND CLEANER

Um . . . ah . . . Kawasaki hand cleaner gets your greasy hands clean. Nothing like hands that are clean, soft . . . smooth . . . slippery . . . ummmm . . .



### VAN CUSTOMIZING

Learn at home in your spare time to customize vans, cars, trucks, choppers and anything else for that matter. Step-by-step guides show you the money-making secrets. For free information write Customizing Center, 4401 Birch Street, Dept. YKOC5, Newport Beach, California 92663.



### SPARE IN A CAN

Are you flat? Ah . . . what I mean is, does your tube . . . ah, I mean if it feels soft . . . er, ah, never mind. Flat tire repair cans are available at your Kawasaki shop.

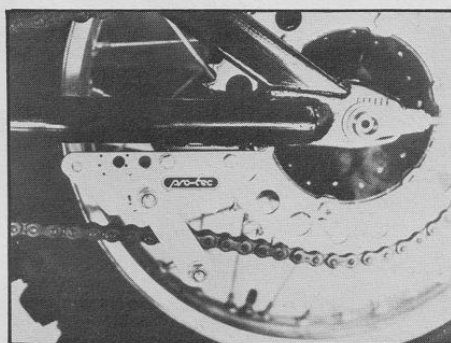

### CHAIN GUIDE/TENSOR

This is a fine investment for your CZ or Maico. This piece of equipment is made from the highest quality materials, and workmanship is superb. You can expect nothing less than the finest from Pete Maly's CMC. Send a dollar to Coast Moto Cycle, Dept. MXA, 2334 Newport Blvd., Costa Mesa, California 92627, or call (714) 645-8008 to get the trick '75 catalog. The S&S chain guide/tensor costs \$24.95.

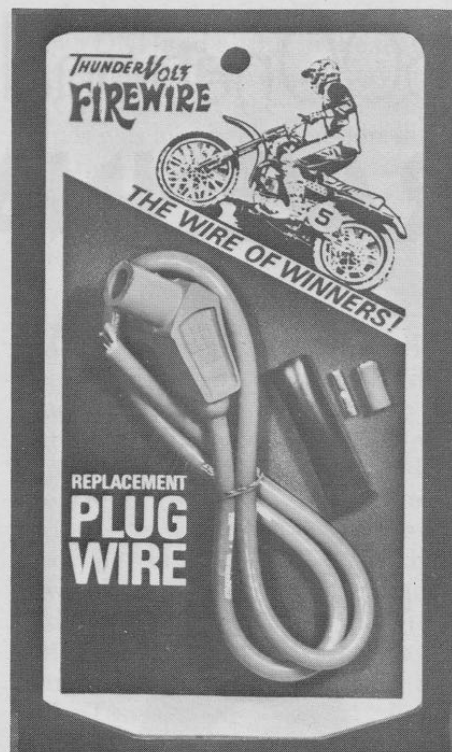

### THE ULTIMATE PLUG WIRE

The Thundervolt Corporation calls this their "Firewire" Motorcycle Kit. It has a flexible silver-plated copper conductor and a silicone insulator/jacket. The silicone spark plug boot is dirt- and water-proof and the whole setup is unaffected by anything Mother Nature can throw at it. \$5.95 per kit. Write Thundervolt Corp., Dept. MXA, 1900 E. Ocean Blvd., Suite 1202, Long Beach, California 90801.



### TEAM JERSEYS

You design it, they make it. Bill Walters makes good jerseys of vented nylon with padded elbows in any colors or styles you want. All the MOTOCROSS ACTION team jerseys and the Team Sideways women's racing jerseys were made by Bill Walters and they are indeed the deluxe items. Write Bill Walters Leathers, Inc., Dept. MXA, 7359 Varna Ave., North Hollywood, California 91506; (213) 982-3738. ☐

# 500national RAVENNA, OHIO

By Jim Gianatsis

The racing has never been better than in this year's 500cc National Championship Series, where trying to pick a winner each week is next to impossible. Any one of ten different riders is capable of taking the win and this fourth race in the five-event 500cc Series was no exception. At Ohio International Raceway near Ravenna, it was Billy Grossi and his Suzuki who surprised everyone by taking the overall win. Few had ever seen Sugar Bear fly so fast as he

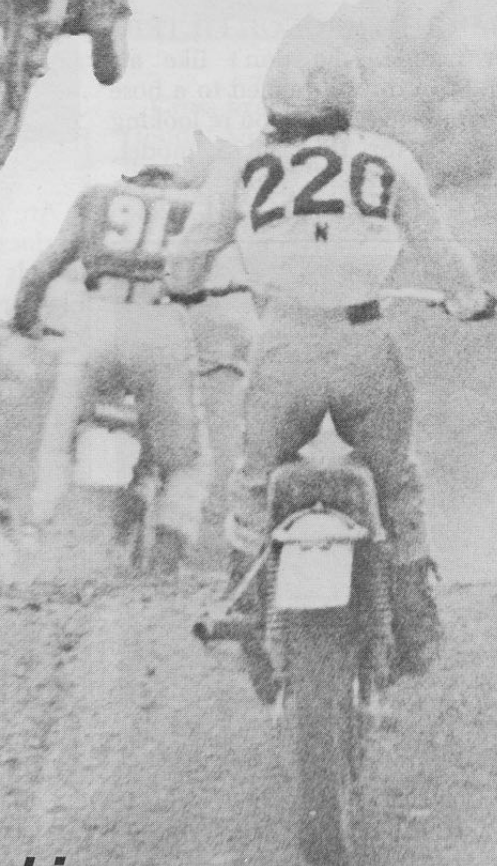

***Billy Grossi takes over the lead in the National Championship Series with one event to go. Suzuki is trying to win the world!***

battled with Brad Lackey and blew the number panels off Pierre Karsmakers and Steve Stackable.

The new track layout at OIR was well over two miles long and contained a natural terrain section that the riders really liked. For Brad Lackey it was ideal, because it resembled some of the courses in Europe. Most spectators chose to stay around the old front section of the course where there was an uphill ski jump and a jump over a muddy

creek. The creek jump proved to be quite an attraction when a lot of riders started doing endos in it, so for the second set of motos it had to be removed from the course.

Making his first appearance in an Open class race this year was Jimmy Ellis on the 355cc Can-Am. This was the big-bore bike which didn't do too well in last year's Trans-AMA Series. Jimmy seemed fast on the bike during the morning's practice session, but an endo with it in the

creek during his qualifying moto, then a DNF and a 13th in the feature motos had the bike on its way back to Canada after the races. Marty Tripes was also back in action in his first race since breaking his collarbone, and he did much better than Jimmy with his factory stock 360 Bultaco.

#### MOTO ONE

After his win at the previous week's National in Virginia, Husky's Brad Lackey was the rider to be watching at Ravenna, but it was Grossi who blasted his Suzuki into the lead of the first moto. Karsmakers, Lackey, DiStefano, Stackable and Savitski gave chase down the high-speed front straight. Bad Brad didn't waste any time sitting behind Pierre as he passed him for second place by the next lap, and Tony Dee followed Brad's example and zapped Pierre right after.

For the first part of the moto positions remained fairly constant; then, at about the 15-minute mark Tony Dee bailed off his RN370 Suzuki, allowing Karsmakers and Stackable to get by. John Savitski had his ride end for the day with a seized engine in his Bultaco. The Jammer, Jimmy Weinert, was also having engine problems with his factory Yamaha and wanted to stop and have mechanic Bill Butchka check it out, but Bill signaled Jimmy to keep racing. The bike went a few laps farther, then quit on Jimmy out on the course. There was some controversy as to whether he received help outside of the mechanics' area to get the bike running again, but a possible disqualification penalty was later dropped. Jim eventually finished the moto in 23rd place, which caused him to lose the lead he had held up to that point for the Championship.

Toward the end of the moto Pierre began to close on Brad for second place, despite the fact that the forks on his RC Honda weren't working properly.

"My damping went out in my forks," Pierre said later, "and I crashed twice because of it. The front forks would just bounce out on me and I would go down." He's running S&Ws on the rear.

Lackey got the signal from mechanic Dean Goldsmith that Pierre was closing in on him. Brad

*Continued*



# RAVENNA, OHIO

said later, "I got the signal that Pierre was moving up on me from behind, so I started getting on the gas more. Soon I found myself catching up with Billy."

With just two laps remaining in the race, Brad smoothly powered his 360 Husky around Sugar Bear to take over the lead and pull away for the moto win. The Bear held onto second place, but not by more than a few bike lengths over Pierre. The three of them were followed across the line by Stackable, DiStefano, Terry Clark and Kent Howerton.

Kent had been taking the race easy because of an injured wrist caused by a snagged front brake cable the week before in Virginia. Husky teammate Mike Hartwig never even began the moto after his old back injury began to pain him during practice. Both Wyman Priddy and Gaylon Mosier had been running well in the moto before they both tangled on a high-speed downhill jump and crashed hard, but managed to walk away from the jumbled mess. Gary Semics didn't finish the moto because of a broken shaft in the gearbox of his works Kawasaki.



**It was Billy Grossi's day at Ohio International Raceway. He won his first 500cc National with his first major win since the Florida Winter-AM Series earlier this year.**

## MOTO TWO

Even though he had missed the first two races of the 500cc Series because he was campaigning the Grands Prix in Europe, it seemed that Brad was well on his way to winning the 500cc National Championship as he pulled into the

lead of the second moto. Brad had the 360 Husky cookin' smooth and fast, just like the previous week when he won in Axton, Virginia. Matter of fact, Brad was looking so smooth that no one noticed that by the fourth lap he was running on a flat tire.

Attention after the start was centered on Tony Dee, who was moving up through the pack, passing Karsmakers, Stackable and Grossi to take over second place. Tony was

*Continued*



**Jammin' Jimmy had a bad day all around. In the first moto his Yamaha quit on him and he pushed across for a finish. In the second moto he jumped the gate and was penalized a lap.**



**A slim Marty Tripes and his wrench Earl Lyons are ready to join the MX wars now that Marty's collarbone is mended. He finished seventh for the day and was lookin' good.**



**Bad Brad is about to zap Karsmakers to take over second in the final moto. It took him two laps to get around the Honda roadblock and Brad later claimed, "Every time I'd pull up beside Pierre he would centerpunch me!"**



# RAVENNA, OHIO

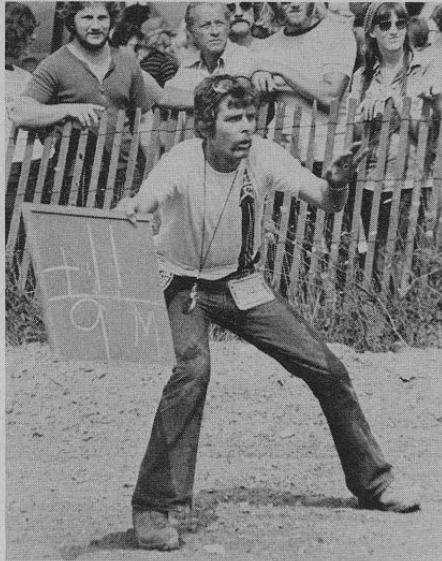

Sugar Bear's mechanic, Brian Lunnis, didn't really need the chalkboard to tell Billy to "cool it" for the final nine minutes. His face mirrors his apprehension. Races like this are tough on guys like Brian.

even beginning to make up some ground on Brad, but he was charging too hard and lost control of the Suzuki, crashing hard. Tony was able to get running again, but was way back in the pack.

Brad was trying to keep the throttle of his Husky pegged despite the flat front tire, but soon Sugar Bear and Pierre began closing in for the kill. Billy pulled his Suzuki up beside Brad in the fast sweeper after the track's uphill ski jump. Brad tried to pick up some more speed in the turn to hold off Billy, but the front wheel of the Husky washed out and Brad went down. Recovering quickly, he got back up in third position behind Billy and Pierre. Just behind Brad, another exciting battle was taking place over fourth place between Weinert, Howerton and Semics.

Things were really heated and the spectators were going crazy as Brad caught back up with Pierre. For two laps he bashed the Husky off the

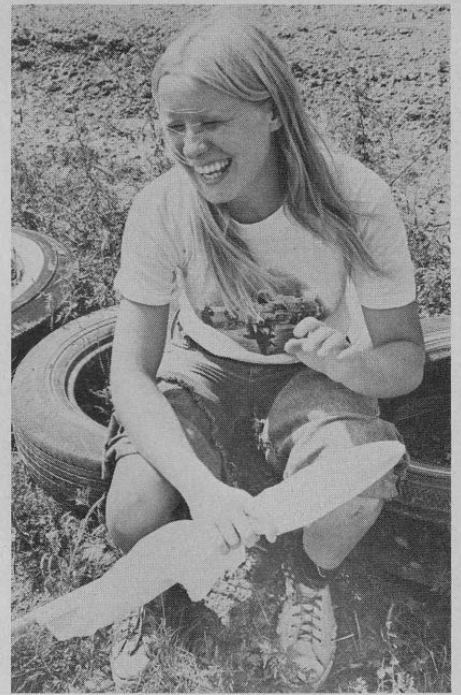

If you got tired watching the racers at Ravenna, you could look at all the cute girl flaggers from nearby Kent State University. Just love those tennies with the argyle socks!



Lackey ran nearly the entire second moto with a flat front tire and almost pulled off his second National win since returning from Europe, but he got a little anxious in trying to pass Grossi and crashed.

Honda's rear fender, trying to get Pierre to let him by.

"Every time I'd pull up beside Pierre, he would centerpunch me!"

Brad finally found room to make a clean pass around the Honda roadblock and began moving after Billy. The flat front tire on his Husky had Brad sliding the bike like crazy in the turns and using up every inch of the track, barely missing trees by inches. He knew that he needed to catch the

Bear for the overall win.

With only two laps remaining in the moto, Brad pulled up behind Billy as they flew 20 feet high off the uphill ski jump and over the heads of the screaming spectators who kept urging Bad Brad to go faster. As they entered the same sweeping turn where Brad and the Bear had tangled earlier, Brad pulled up alongside Billy on the outside. Then, just as it had gone down before, the

front end of the Husky washed out. This time Brad went through the snow fence on the outside of the turn and spent a lap trying to get running again, finishing the moto in 12th. Everyone just groaned.

Billy Grossi was obviously excited as he crossed the finish line in first place to garner the win for Suzuki. For the Bear and for his happy mechanic Brian Lunnis, it was their first major victory this year since the Florida Series. It also put them in the points lead for the Championship going into the final round at New Orleans.

Finishing out the final moto in second place was Pierre Karsmakers, who ended up with second overall for the day ahead of Stackable and Howerton. Fastest independent was Terry Clark in fifth. Jimmy Weinert compounded his first moto problems by jumping the gate in the second moto and receiving a one-lap penalty. Tony DiStefano finished out the moto with a broken frame on his Suzuki.

#### 250 SUPPORT CLASS

Despite doing an endo at the creek jump during the first moto (check "Bermshot"), Bob Rutter from Benton Harbor, Michigan, easily ran away with both motos on his Bultaco to take the Support class. Last week's winner in Virginia, Sam Dayton, got to hold down first place for a while after Rutter crashed in the mud, but eventually had to settle for second overall ahead of Shane Hruska on a Yamaha.

#### RESULTS 500cc NATIONAL

1) Billy Grossi (2-1) .....	Suz
2) Pierre Karsmakers (3-2) .....	Hon
3) Steve Stackable (4-5) .....	Mai
4) Kent Howerton (7-4) .....	Hus
5) Terry Clark (6-7) .....	Hus
6) Brad Lackey (1-12) .....	Hus
7) Marty Tripes (10-6) .....	Bul
8) Bob Harris (11-8) .....	CZ
9) Tony DiStefano (5-14) .....	Suz
10) Wayne Boyer (12-11) .....	CZ
11) Jim West (9-16) .....	Mai
12) John Ayers (20-9) .....	Mai
13) Pat Richter (19-10) .....	CZ
14) Steven Floyd (13-9) .....	Bul
15) Thomas Wendell (17-20) .....	Mai
16) Jim Weinert (23-15) .....	Yam
17) Mark Blackwell (21-17) .....	Hus
18) Gary Chaplin (8-30) .....	CZ
19) Carl Zortman (18-21) .....	Yam
20) Scott Jordan (14-27) .....	Bul

#### 250cc SUPPORT

1) Bob Rutter (1-1) .....	Bul
2) Sam Dayton (2-2) .....	Bul
3) Shane Hruska (3-3) .....	Yam
4) Jeff Bonasera (8-4) .....	
5) Jack Mayer (9-9) .....	C-A
6) Scott Ultmann (14-5) .....	
7) Haworth Jones (11-10) .....	Yam
8) Scott Hall (13-12) .....	Hus
9) Jeffrey Woodrow (23-7) .....	Hus
10) Danny Steinen (19-13) .....	Hus



Steve Stackable put in another consistent ride for third for the day. Check out the Marzocchis on the rear.



Lauri Lackey and Cathy Clark speak to a film crew about the life of a motocross wife. The crew has been following the 500cc National Championship, which will be released as a movie at a later date.

# GETTING YOUR HEADS STRAIGHT

## *A test and comparison of popular accessory cylinder heads*

Boy, are we getting Naderesque. The boss gave us a pep talk last week about how consumerism "sells," so we had to come up with a big deal, shoot-'em-up product comparison. So, basic to the nature of our staff, we picked something easy. What could be easier than whipping

cylinder heads on and off a CR125? That's a four-nut operation if you don't count the spark plug. Besides, from the looks of our mail and what they're running at the local tracks, it seemed like something in the way of information on CR125 cylinder heads was needed. So we did it.

### PROCURING THE STUFF

Nothing to it. We called Webco, DG Performance Products, Flying Machine Factory, Ocelot Engineering, Norris Cycle Products and T&M Engineering, all manufacturers and distributors of popular CR125 accessory cylinder heads, and told them what we were going to do. They all sent us one except for DG. They sent us two, both the same. We also procured a "special" FMF head for limited testing.

The FMF porcupine head. It looks trick but its effectiveness is limited.

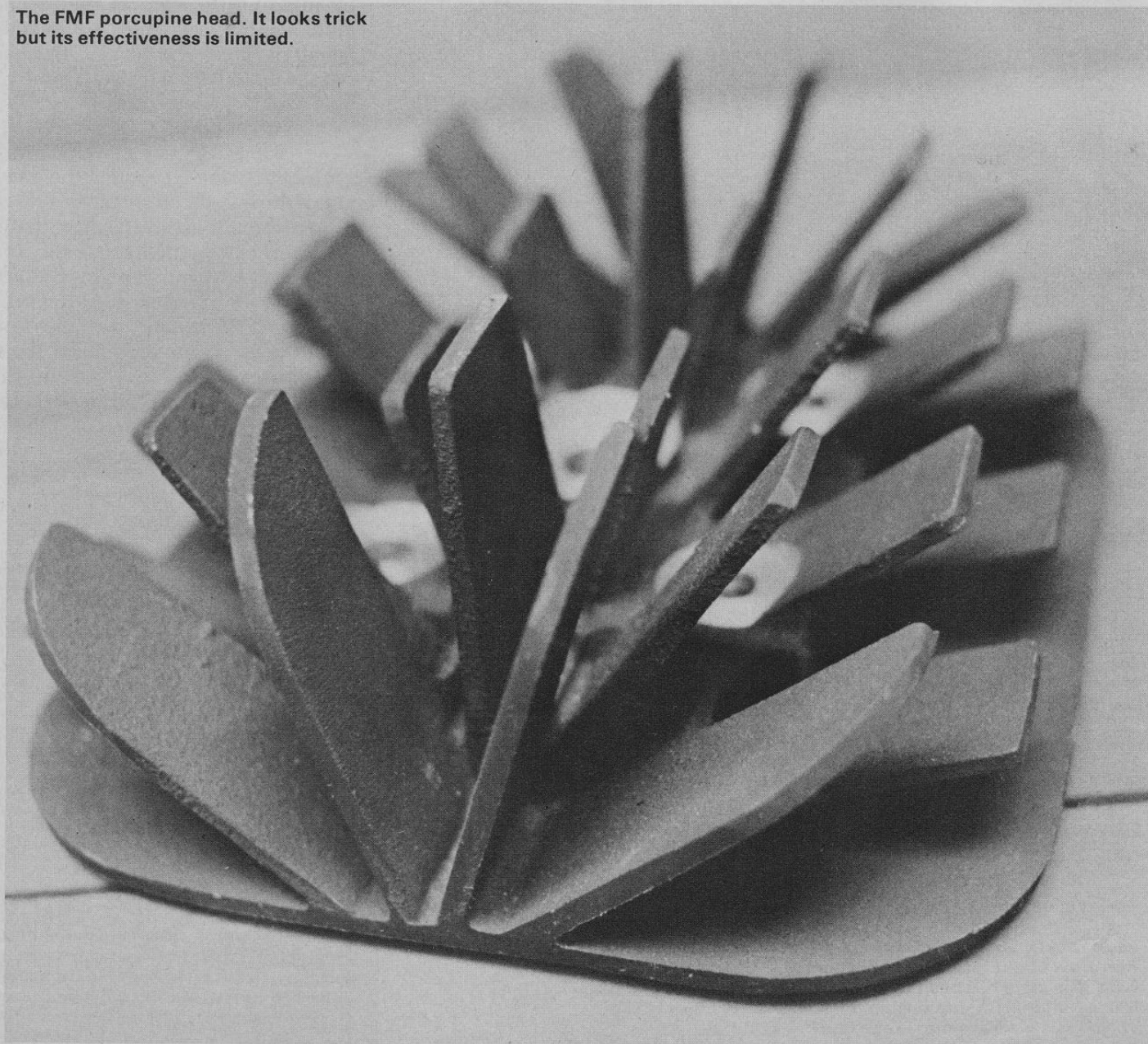

## FIGURING OUT THE TEST

For this we contracted Butch Linden of Goleta Valley Cycles in Goleta, California. Butch is a hot District 37 Expert and holds the current #3 plate in 125 motocross. He is an engineer and knows a lot about metals, heat flow and testing procedures. He also knows a lot about motorcycles, especially Bultacos and Pentons, and he's got a dynamometer. He's also a lot of fun to fool around with.

Together with Butch, we decided the test should include an overall inspection plus measurement of the properties of each head. The test would measure weight, combustion chamber volume, cranking pressure, horsepower readings, operational temperature, temperature peak and cool-down time.

## INSPECTION

Each head was inspected right out of the box as it arrived. Surface measurements of the combustion chamber were also taken at this time. All the heads with the exception of the DG were cast in aluminum of around the 356 alloy number, T6 heat treated and sand-blasted. The DG head was an extrusion — which means a bar of hot aluminum was pushed through a die under tremendous pressure to form the blank which is then drilled and machined. It is a less expensive process that achieves about the same results. The Webco and FMF heads are black anodized and the rest are left natural.

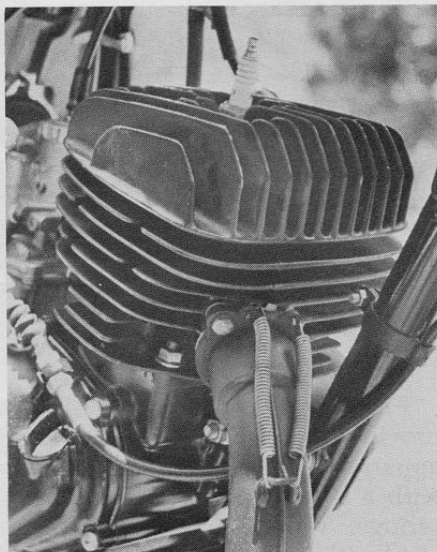

If you don't mind the untrick looks of the stock head, it will do you pretty good. Good horsepower readings when cold are offset by high temperature peaks under load.

Only the FMF and the DG were true radials, the plane of each fin focusing on a point within the combustion chamber. The FMF head has a porcupine fin arrangement. The Ocelot, NCP and T&M were "sunburst" style with their fins radiating from a locus well below the combustion chamber like on the new Huskys. The Webco head, which had the most fins, had vertical fins like the stock head and also had fins under its base.

All the heads had a single, centrally located plug hole.

In order to get some idea of the casting quality, we examined the machined surface of the combustion chambers for pits which would indicate bubbles in the castings. These tiny bubbles would tend to cause hot spots on the combustion dome during operation, which would tend to cause detonation or pinging if the spots got hot enough. The Webco, DG and FMF heads, along with the stock head, showed no pits at all. The T&M had a few and the Ocelot and NCP had a bunch.

Most cylinder heads have an exhaust bias. This means there are larger fins and more material on the exhaust side of the head than on the intake side, or at least the combustion chamber is offset to the intake side to provide the exhaust side with more meat. This is done because the exhaust side runs hotter and requires more cooling capacity. The FMF and Ocelot heads were not exhaust biased, but the rest were.

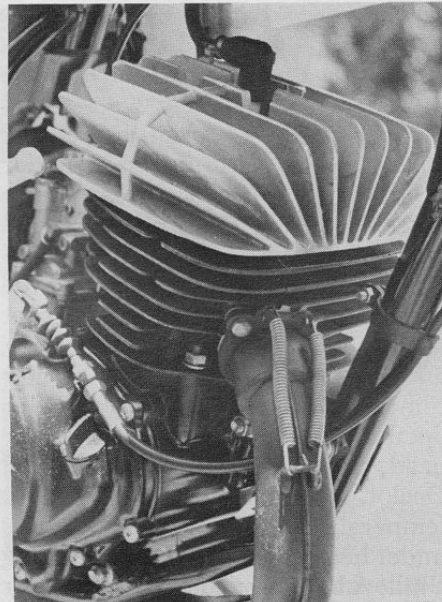

The T&M head looked very impressive in both temperature ranges and performance figures.

Only the Webco and Ocelot heads came with any kind of instructions. The instructions warned that if the heads were used with the Honda GP barrel, piston-to-head clearance should be checked and extra gaskets used if necessary. The instructions also noted the torque settings to make on the head nuts. Webco said 220 inch/pounds and Ocelot said 125 inch/pounds. We used 220 inch/pounds on all the heads to maintain a standard. None of the other heads included any instructions other than the shipping order. The DG head came with a brochure on all the DG products and a bunch of DG stickies.

Combustion chamber shapes varied. A spherical combustion chamber provides the best environment for efficient burning so therefore tends to be the most desirable. The cone segment combustion chamber, like the stock chamber, reduces thermal loads on the piston and mechanical loads on the rod and bearings, but is less efficient. The Webco, DG and FMF heads have spherical combustion domes. The rest have cone segment domes. FMF offers a torus shaped dome on their special head which is a somewhat flattened sphere and is supposed to give better power, but we found no significant differences between the special FMF head and the regular FMF head.

We noticed that the DG head had a stud hole that wasn't reamed through all the way, and it needed to be filed a bit before it would go

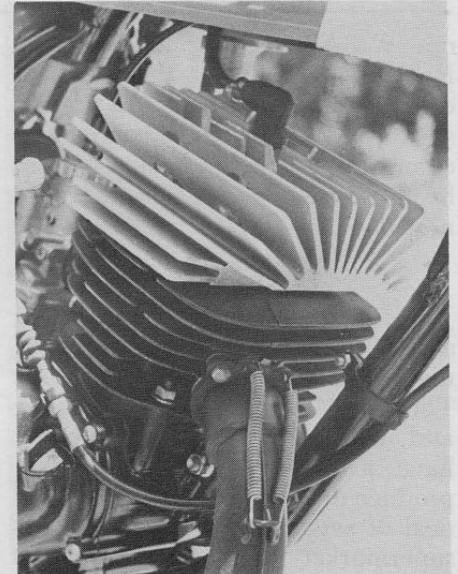

Least expensive was the DG head, a one-piece extrusion. Its high cranking pressure could negate any money saved by eating a piston.

## HONDA CR125 HEAD TESTS

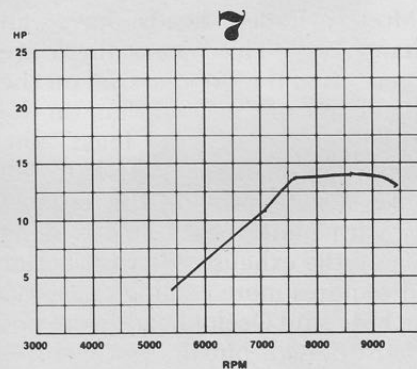
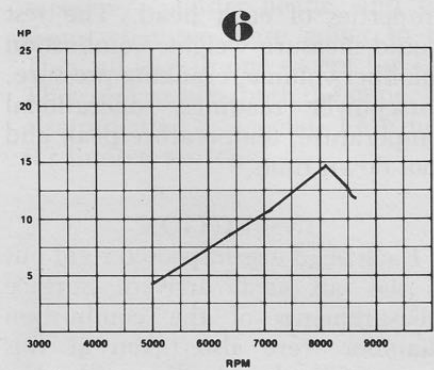
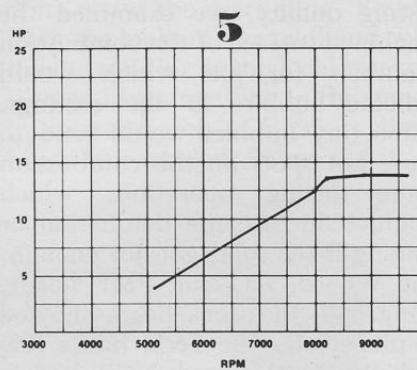
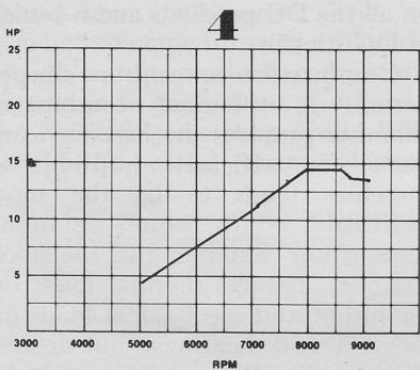
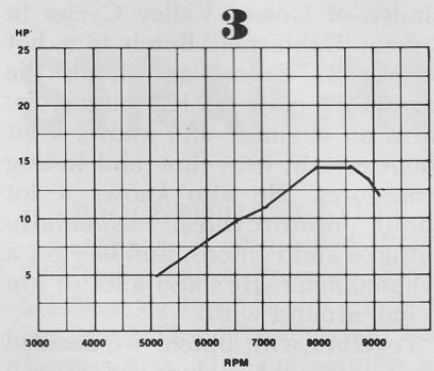
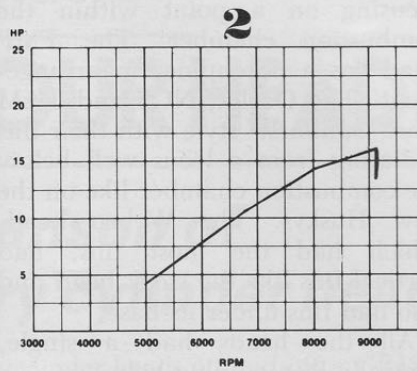
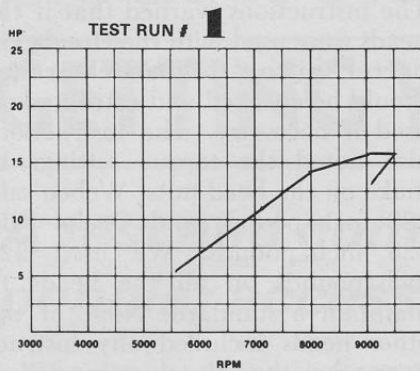

### TEST RUN

- 1 - STOCK
- 2 - WEBCO
- 3 - DG
- 4 - FMF
- 5 - OCELOT
- 6 - NCP
- 7 - T&M

All runs in fourth gear.  
Head temperature brought to 200 degrees F before run started.

on. We were about to tell Gary Harlow of DG about this when he called to tell us they had just made a slight change in their combustion chambers and two of the up-dated heads would arrive at our offices the next day.

### WEIGHT

This time we called in as our expert the Smith's Food King supermarket in Carpinteria, California. They have very friendly checkers and are open 24 hours. They also have a real nice scale in their produce department. It takes a great deal of *savoir faire* to walk into a supermarket with a box full of cylinder heads and weigh them one by one on the produce scale. We of course put a plastic baggie on the

bottom of the scale to keep things sano. And the checkout lady didn't bat an eyelash when we walked through with a dozen eggs, two bags of Oreos and seven cylinder heads in our shopping cart. The bagger even put them in a sack and said thank-you.

Keep in mind when studying the weight figures on the chart that more weight comes from more mass and more mass means greater temperature consistency under operating conditions. A heavier head, like the Webco, DG and Ocelot, tends to keep a constant temperature even when the bike is under heavy load like when climbing a hill. A lighter head like the FMF or

the stock head would tend to heat more quickly under load, and the chances rise that you might reach a critical temperature before you get to the top of the hill. It's interesting to note here that the cylinder heads on the super-trick RC125 Hondas raced in National and International competition are made of a copper alloy and weigh *twelve* pounds each.

### CYLINDER HEAD VOLUME

For this test Butch Linden provided us with the measuring apparatus: a piece of flat plexiglass with a small hole in it and a horse syringe. We secured each cylinder head with a spark plug installed and the combustion chamber facing up,

# GETTING YOUR HEADS STRAIGHT

smears a little grease around the edges and places the plexiglass over it with the hole in the middle, then injects a measured amount of oil through the hole into the combustion chamber with the horse syringe. Did you ever see a horse syringe? If the Jolly Green Giant was a junkie, he'd use a horse syringe.

The chamber volume determines compression. A large volume means low compression and a small volume means a higher compression. Only the Ocelot head had the same volume as the stock head. The rest were smaller in order to increase performance. You can see some correlation between the chamber volumes, horsepower readings and cranking pressures. Keep in mind that as compression rises, so do piston crown temperatures. The NCP head, showing the lowest volume, would produce very high compression and put the heaviest loads on your piston, connecting rod and bearings. The Ocelot head, along with the stock head, would be easiest on your engine.

During this test we noticed that the spark plug hole on the DG head was incorrectly machined. We were just about to contact them when, wouldn't you know, Gary Harlow from DG called again and told us they had this new head with a slight change in it which would be the one they would be selling, and that we'd be getting two more the next day. As it turned out, the previous two (or rather four) heads we got from DG were prototypes, and the next two

would be production items and shouldn't have any mistakes in them. We were delighted. We also had an office full of DG doorstops, paperweights and ashtrays.

#### CRANKING PRESSURE

Modern two-stroke thinking dictates combustion chamber pressures be measured in terms of cranking pressure rather than compression ratio, since the compression ratio may change with exhaust port modifications and a lot of other reasons we don't even know about. Cranking pressure is measured by screwing a special pressure gauge into the spark plug hole and kicking the motor till a maximum reading is obtained.

Any pressure reading over 135

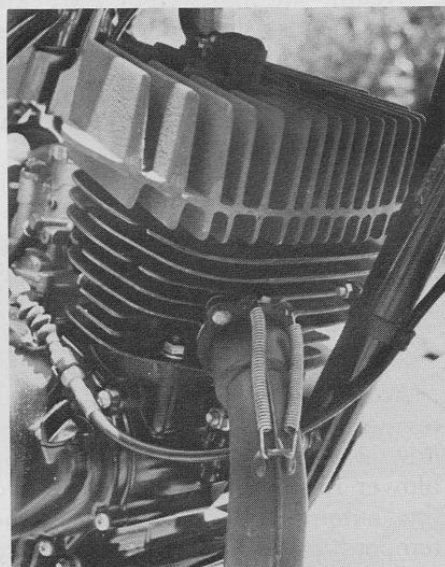

**The Webco head produced the best numbers and was the second cheapest. It looks like the best all-around buy.**

pounds is considered high performance. Most tuners feel something in the area of 165 pounds is optimum for 125s. Anything over that is putting heavy loads on the parts. In other words, the NCP and DG heads may get you some good horsepower if you tune into them, but the longevity of your engine may suffer. On the other side of the coin, the stock head and the Ocelot will treat your rod with tender loving care.

#### HORSEPOWER

Horsepower readings were taken on the Goleta Valley Cycle dyno with Butch Linden at the controls. We used a new Honda CR125M1 running 40:1 Bel-Ray with a stock head gasket and the head nuts torqued to 220 inch/pounds. We used the stock pipe and the stock jetting and made no attempt to retune the engine after changing heads.

The nicest powerbands came out of the Webco, T&M and, surprisingly, the stock heads. The NCP head, with its high cranking pressure, predictably produced the most grunt. The Ocelot revved the highest, possibly the product of its lower compression. We experienced erratic running with the DG head but felt it was influenced by other factors such as tuning.

These horsepower readings shouldn't be given any more weight in this test than any of the other measurements. Horsepower comes from many things besides cylinder heads. We put them in because they

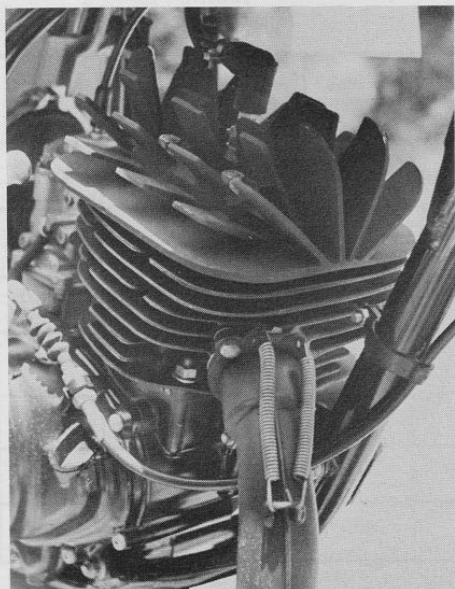

**The FMF was the lightest but it produced a very high temperature peak under load. It was the most expensive.**

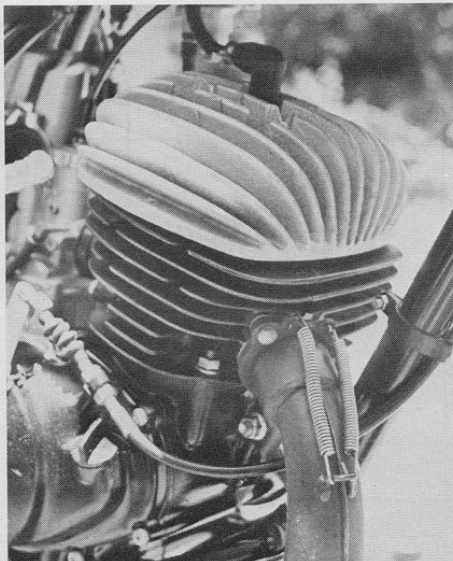

**If you're looking for a good, dependable head that won't blow your engine, the Ocelot is the perfect buy. It also gives you a couple hundred more rpm.**

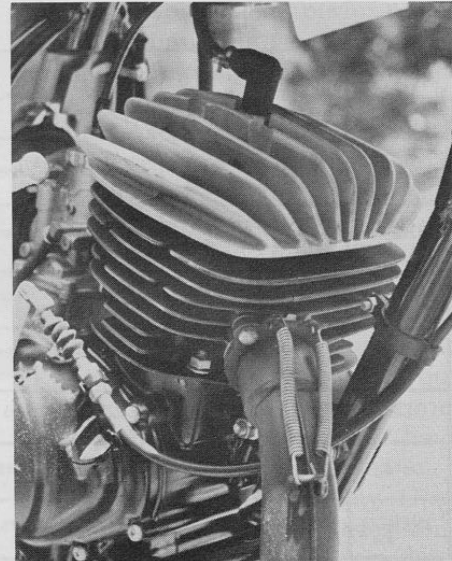

**Good grunt, cooling and low price keep the NCP head in the running. An excessively high cranking pressure could do your engine in, however.**

were easy to get while taking temperature readings on the dyno, so we thought you might like to dig on them a little.

### OPERATIONAL TEMPERATURE

While making the horsepower runs on the dyno, we noted the average temperatures taken at the spark plug. The horsepower runs weren't made until the spark plug temperature reached 200 degrees; then the run was made and the average operational temperature was determined. This test gives you some idea of how hot your head will be running in relationship to the others during a race.

All the heads ran cooler than the stock head. The lowest-pressure, heavier Ocelot predictably showed the lowest temperature. The lightweight, higher-pressure head, the FMF, showed a hotter reading. Strangely, the high-powered NCP head, although not nearly the heaviest, showed the second lowest operating temperature.

Temperature and horsepower work against each other. Power produces heat, but heat robs power. You have to get something in the middle.

### PEAK TEMPERATURE

At the end of each horsepower test, we ran the engine at full power under heavy load for exactly 60 seconds and recorded the peak temperature reading. This test determines how fast and how high your cylinder head temperature is

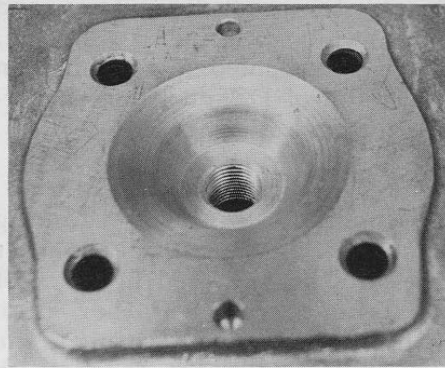

This is a cone segment combustion chamber. Those tiny pits on the machined surfaces indicate bubbles in the casting and could cause hot spots during operation.

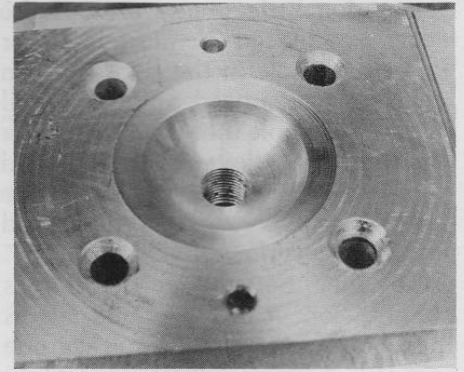

This is a spherical combustion chamber. Smooth finish indicates a good casting, or in this case, an extrusion. The narrow band around the outside of the combustion chamber is called the "squish band."

going to go up when you start through deep sand or up a long hill.

Again, the lightweight FMF and stock heads showed the highest readings. Most significant was the T&M, which showed a good powerband but a very low peak temperature.

Heat kills. As the engine temperature rises above its normal operating level, the chances for seizure and piston failure rise with it.

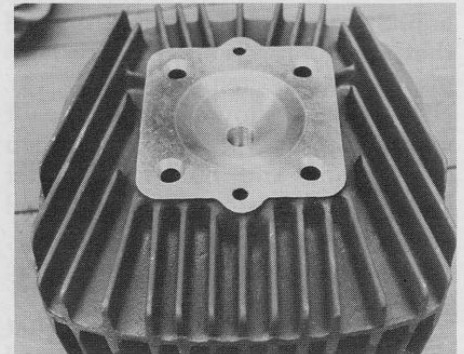

The Webco was the only head to sport underfinning.

### COOL-DOWN TIME

After the 60 seconds of the peak temperature test were up, we shut down the engine and left the cooling blower running. We then recorded the amount of time it took the temperature to fall from its peak to 200 degrees. This test shows, to some degree, how fast each head can dissipate heat. It would seem the

lighter heads would cool more quickly just as they heated up more quickly, and the heavier heads, because their greater mass holds the heat longer, would tend to cool more slowly.

Two interesting exceptions were the T&M and the DG. The T&M, which was the same weight as the

### MOTOCROSS ACTION HEAD TEST

	Weight	Number of fins	Pits (see copy)	Exhaust bias	Combustion chamber shape	Squish band	Combustion chamber volume (cc)	Cranking pressure (psi)	Peak horsepower (rear wheel)	Operating temperature (°F) +	Temperature peak (°F)	Cool-down (sec.)	Price (\$)
STOCK	1¾	13	0	yes	cone	5/16"	15	150	15.1	260	310	62	\$28.00
DG	4	15	0	yes	sphere	1/4"	13.5	175	14.7	240	290	126	\$39.95
FMF	2½	9*	0	no	sphere	5/16"	14	169	14.7	250	320	75	\$57.00
NCP	3¾	9	45	yes	cone	3/8"	13	187	14.7	225	290	92	\$39.95
OCELOT	4	13	22	no	cone	7/16"	15	148	13.7	210	265	73	\$49.95
T&M	3¾	11	3	yes	cone	3/8"	14.5	160	14.7	240	270	47	\$49.95
WEBCO	4¾	17†	0	yes	cone	5/16"	14.5	158	15.7	240	295	73	\$44.95

\* porcupine

† plus underside finning

+ taken at the spark plug

# GETTING YOUR HEADS STRAIGHT

Different finning styles are shown here clockwise from upper left: The DG head is a true radial, the Webco has vertical fins with underfinning, the NCP is a sunburst style and the FMF is a radial porcupine.

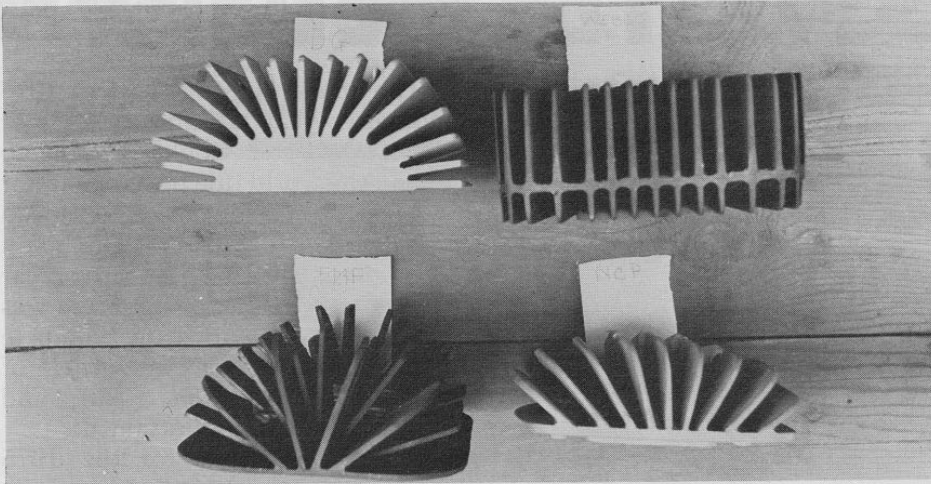

Cooling air is directed around the combustion chamber by the radial finned DG head and by the angles of the vertical finned Webco. Notice the exhaust bias of both.

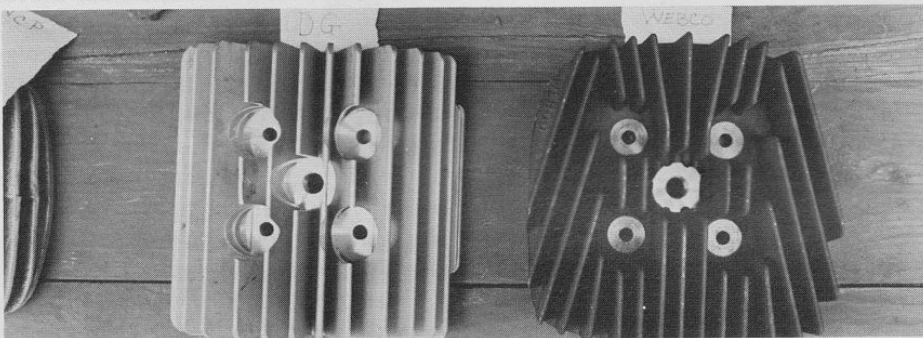

The Goleta Valley Cycle dyno, Butch Linden's pride and joy.

A sticky Pirelli TT tire was used to keep a good contact with the roller.

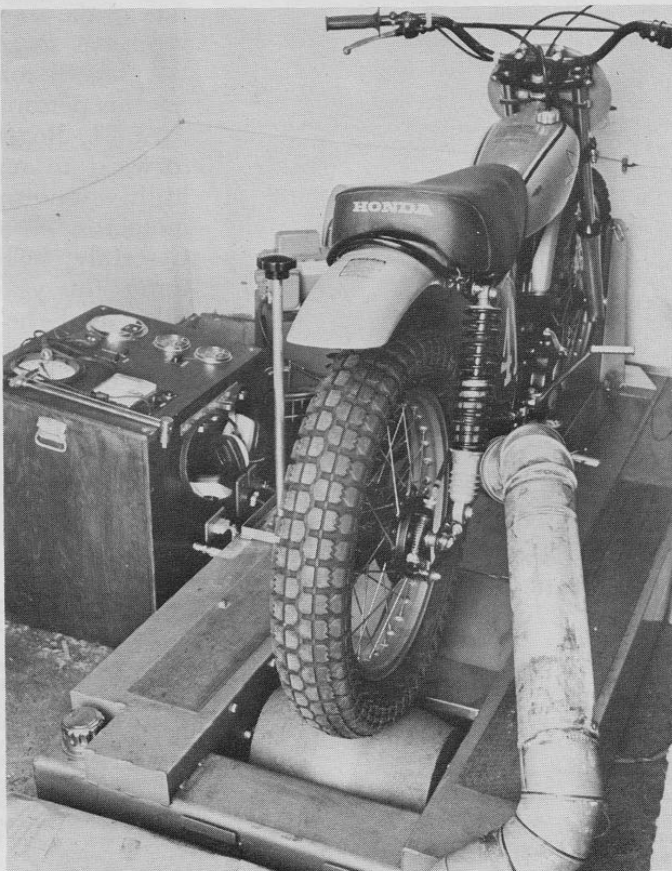

NCP, cooled down in half the time, and scored the fastest time. The DG, probably because of its denser extrusion, took the longest to cool down.

Cool-down time would show a head's ability to return to normal operating temperature after heavy loads, like climbing that hill. A head with a fast cool-down would get your bike running normally again before the next hill.

#### PRICE

Retail price tells a big story, especially if you're strapped for the bucks. The DG is the cheapest of the accessory heads because of its production technique, a simple one-piece extrusion. The NCP shares low price with DG, but its casting tells the story. You pay a premium for the FMF head because it is a seven-piece casting and takes some doing to manufacture. Everything else in the middle is in the middle. When put up against the competition, however, the stock head looks like a pretty good bargain, but you get one of those thrown in with every new bike.

#### CONCLUSION

The Webco head looks like the best deal. It produced desirable results in all the tests and is lower priced than every head but the DG. The DG and T&M heads are also good buys, the DG because of its quality and price and the T&M because of its performance. The Ocelot head is an excellent choice if you're looking for something that will give you good performance while still maintaining a comfortable reliability margin. The FMF head seems too high-priced to justify its high temperature peak. The high cranking pressure of the NCP head is setting your engine up for a breakdown and probably is best to avoid unless you're looking for high output at any cost.

We hope you are now better able to make a wise choice when buying an accessory cylinder head for your CR125. With our limited time, facilities and manpower we have tried to give you some idea . . . what? What's that? You say Gary Harlow from DG is on the phone and they've now developed a porcupine head and we should get two in the mail by tomorrow? Good. That's all we need — more heads. 

# 500 world champion ROGER DECOSTER, BELGIUM

**Team Suzuki**

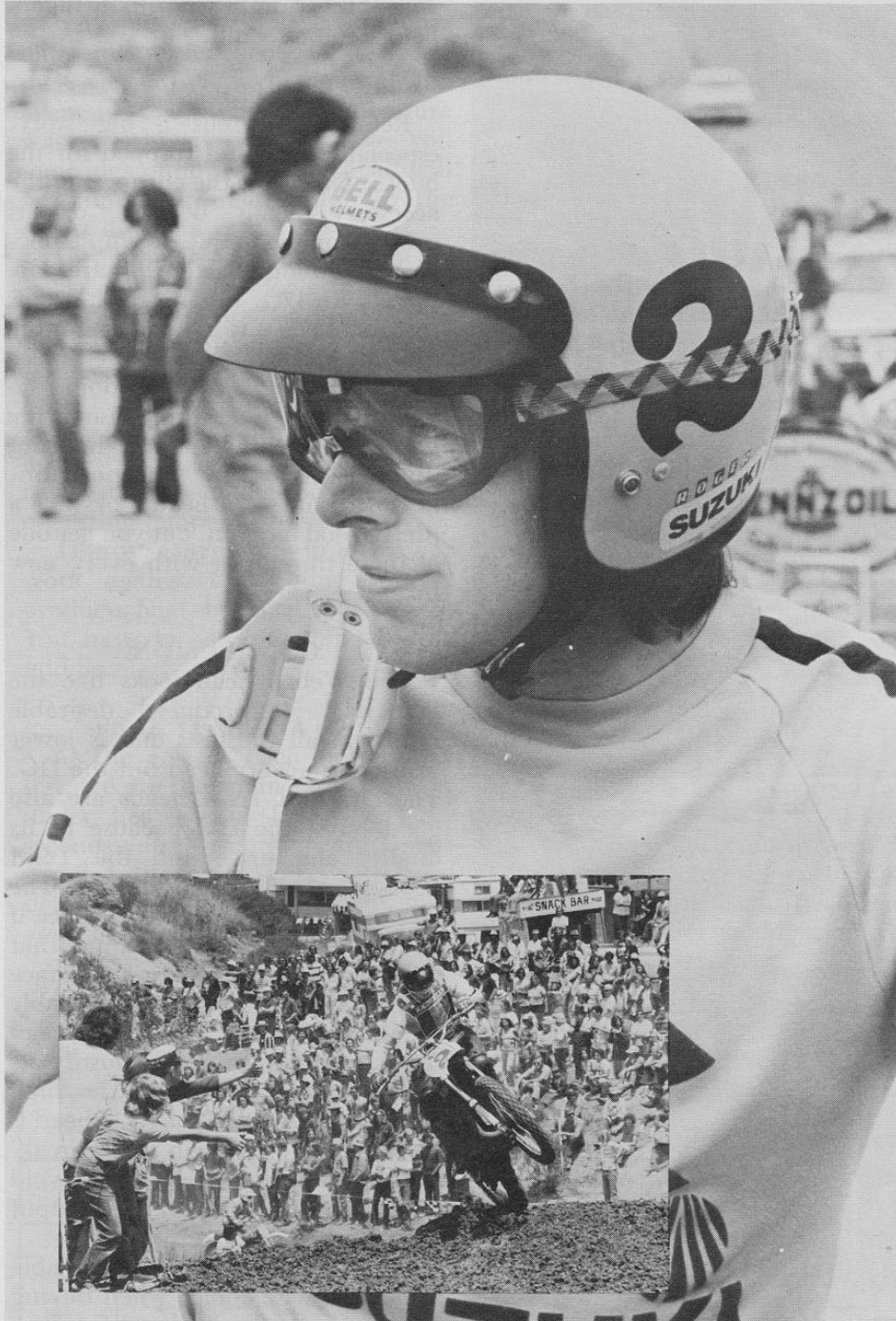

The main question as the 1975 motocross year began was whether Roger DeCoster would be able to regain the world title he had held for three straight years prior to Heikki Mikkola's 1974 victory. The main question as the 1975 motocross year ended was whether or not there was anyone who could truly compete with DeCoster on the level of personal preparation, skill and concentration he has attained.

The points totals for the 1975 season are not truly indicative of the extent to which the Belgian dominated Open class motocross during his comeback charge. DeCoster won 13 Grand Prix motos outright. His nearest competitor, Heikki Mikkola, won four. He was overall winner of seven international Grands Prix. Gerrit Wolsink, with three overall victories, was the only other rider to win more than one overall. In contrast to the down-to-the-wire battles of previous years in the Open class, Roger DeCoster had assured his record-setting fourth World Championship by the ninth race of the season. No man in recent years has so completely dominated the class by force of both his riding and his personality.

At 31, Roger DeCoster can look forward to several more years of highly competitive, winning motocross — if he wants them. Certainly, he'll be in the thick of things this year, vying for his fifth title, and he'll be the odds-on favorite to win. How long he can hold off the charges of younger, hungrier riders will depend upon how long he can maintain the competitive edge and desire which set him head and shoulders above everyone in motocross in 1975. **III**

## 1975 500cc GRAND PRIX RESULTS

RACE	1st MOTO	2nd MOTO	OVERALL
Switzerland	DeCoster	Mikkola	DeCoster (1-2)
Italy	Hammargren	Mikkola	Mikkola (3-1)
Finland	DeCoster	DeCoster	DeCoster (1-1)
U.S.S.R.	Jonsson	DeCoster (2-1)	DeCoster (2-1)
France	DeCoster	DeCoster	DeCoster (1-1)
U.S.A.	DeCoster	Wolsink	Wolsink (3-1)
Canada	DeCoster	Wolsink	Karsmakers (2-2)
England	Mikkola	DeCoster	Wolsink (2-2)
West Germany	DeCoster	DeCoster (1-1)	DeCoster (1-1)
Netherlands	Wolsink	DeCoster	Wolsink (1-2)
Belgium	Mikkola	Jonsson	DeCoster (2-2)
Luxembourg	DeCoster	Lackey	DeCoster (1-2)

## 500cc GRAND PRIX FINAL STANDINGS

- 1) Roger DeCoster, Belgium (192).....Suzuki
- 2) Heikki Mikkola, Finland (165).....Husqvarna
- 3) Gerrit Wolsink, Netherlands (149).....Suzuki
- 4) Ake Jonsson, Sweden (132).....Yamaha
- 5) Jaak van Velthoven, Belgium (104).....Yamaha
- 6) Brad Lackey, U.S.A. (100).....Husqvarna
- 7) Bengt Aberg, Sweden (75).....Bultaco
- 8) H. Schmitz, West Germany (62).....Puch
- 9) Arne Kring, Sweden (48).....Husqvarna
- 10) Pierre Karsmakers, U.S.A. (45).....Honda

# 250 world champion HARRY EVERTS, BELGIUM

## Team Puch



(Szilagyi photo)

In a year of runaways in the 125 and 500 Grand Prix classes, it was the 250 class which provided the melodrama and week-by-week changes of a highly competitive race. West German Suzuki rider Willi Bauer and Puch's Belgian ace Harry Everts fought for the lead throughout the season, with Hakan Andersson, Adolf Weil, Jaroslav Falta (prior to his season-ending illness) and the brilliant but inconsistent Zdenek Velky breathing down the leaders' necks. In the end, it was Everts' consistency which won him the title.



(Maltais photo)

Familiar to Americans through his fifth-place finish in the 1974 Trans-AMA Series, Everts wins races in the same way that he wins championships, waiting in the wings for some sign of weakness, some inconsistency or slowing of the pace, then pouncing for the victory. It is characteristic of his style that he turned the season-long 250 battle into a moderately easy win at the end, winning going-away by 25 points.

The 1976 Grand Prix season should see the return of '74's champion Guenady Moiseev, and perhaps of Jaroslav Falta, to the 250 race, and things will grow even more complicated. Meanwhile, riders like Velky and America's Jim Pomeroy continue to improve. Things won't be any easier for Harry Everts next year.

### 1975 250cc GRAND PRIX RESULTS

RACE	1st MOTO	2nd MOTO	OVERALL
Spain	Andersson	Weil	Everts (2-3)
Austria	Falta	Falta	Falta (1-1)
Belgium	Pomeroy	Andersson	Pomeroy (1-5)
Czechoslovakia	Velky	Falta	Bauer (4-2)
Poland	Everts	Everts	Everts (1-1)
Yugoslavia	Velky	Everts	Everts (6-1)
West Germany	Hansen	Velky	Velky (2-1)
England	Everts	Andersson	Everts (1-2)
France	Weil	Velky	Velky (2-1)
Sweden	Everts	Maisch	Maisch (4-1)
Finland	Moiseev	Andersson	Mikkola (2-3)
Switzerland	Hansen	Everts	Andersson (3-4)

### 250cc GRAND PRIX FINAL STANDINGS

- 1) Harry Everts, Belgium (159) ..... Puch
- 2) Hakan Andersson, Sweden (134) ..... Yamaha
- 3) Willi Bauer, West Germany (130) ..... Suzuki
- 4) Adolf Weil, West Germany (129) ..... Maico
- 5) Hans Maisch, West Germany (117) ..... Maico
- 6) Zdenek Velky, Czechoslovakia (108) ..... CZ
- 7) Jim Pomeroy, U.S.A. (101) ..... Bultaco
- 8) E. Rybaltchenko, U.S.S.R. (94) ..... CZ
- 9) Joel Robert, Belgium (85) ..... Suzuki
- 10) Torleif Hansen, Sweden (66) ..... Kawasaki

# 125 world champion GASTON RAHIER, BELGIUM

**Team Suzuki**

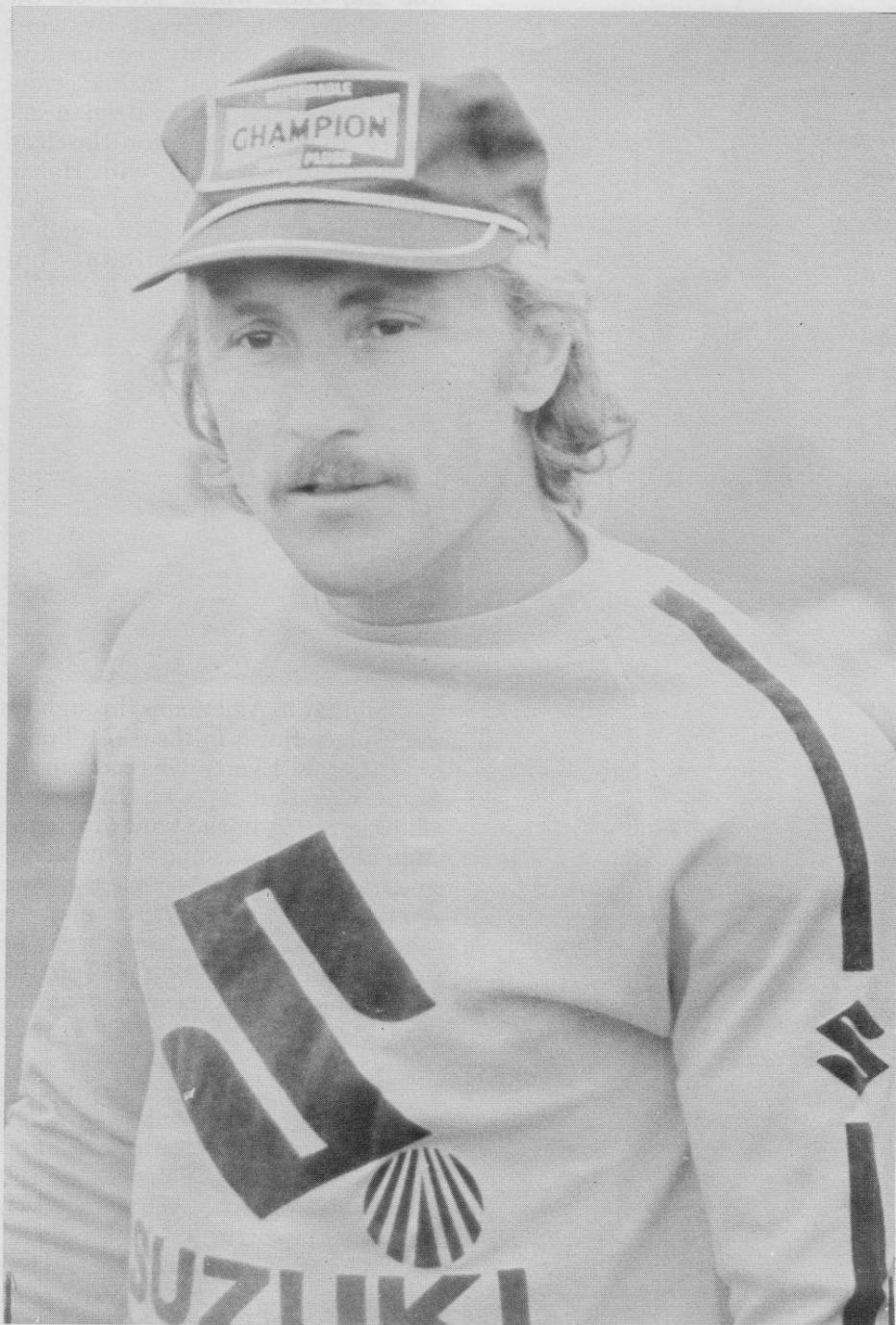

It wasn't much of a year for close contests in the 125 class. While Marty Smith was wiping up the competition here at home, in Europe Gaston Rahier was dominating the new 125 Grand Prix class in a way that no other GP class has been dominated before. In recent years the European 125 class has been the property of Zundapp and Andre Malherbe, but Suzuki's new 125 GP machines proved to be both faster and lighter than the German bikes. At the same time, Rahier, a Belgian who has raced the 250 class for Suzuki in past years, was proving that as a 125 rider he probably has no equal.



(Gianatsis photo)

Rahier won 14 motos on his way to his first World Championship, icing the title by the eighth race of the season. He also won eight Grands Prix overall, adding to his bank account and Suzuki's general delight.

As a rider at the top of his form, with years of Grand Prix experience under his belt, and riding the dominant bike in the class, Rahier will be the obvious favorite in the class this year. But with Andre Malherbe back in shape after an early season injury last year, and with the development work that the Zundapp factory is certain to do over the winter, Gaston may find holding onto his title a little harder than getting it was.

And then there's another question: where will Marty Smith be racing this year?

#### 125cc GRAND PRIX FINAL STANDINGS

- 1) Gaston Rahier, Belgium (195) . . . . . Suzuki
- 2) Gilbert DeRoover, Belgium (167) . . . . . Zundapp
- 3) Antonin Baborovsky, Czechoslovakia (135) . . . CZ
- 4) Akira Watanabe, Japan (134) . . . . . Suzuki
- 5) Jiri Churavy, Czechoslovakia (99) . . . . . CZ
- 6) V. van Brock, Belgium (79) . . . . . Husqvarna

#### 1975 125cc GRAND PRIX RESULTS

RACE	1st MOTO	2nd MOTO	OVERALL
France	Rahier	DeRoover	Rahier (1-3)
England	Rahier	Rahier	Rahier (1-1)
Yugoslavia	Rahier	Rahier	Rahier (1-1)
Sweden	Rahier	Rahier	Rahier (1-1)
Netherlands	Rahier	Rahier	Rahier (1-1)
Poland	DeRoover	DeRoover	DeRoover (1-1)
West Germany	Rahier	Rahier	Rahier (1-1)
Czechoslovakia	Rahier	Rahier	Rahier (1-1)
U. S. A.	Smith	Smith	Smith (1-1)
Canada	Sugio	DeRoover	Baborovsky (2-2)
Spain	Watanabe	Watanabe	Watanabe (1-1)
Belgium	Rahier	Rahier	Rahier (1-2)

# 500 national champion JIM WEINERT, TEAM YAMAHA

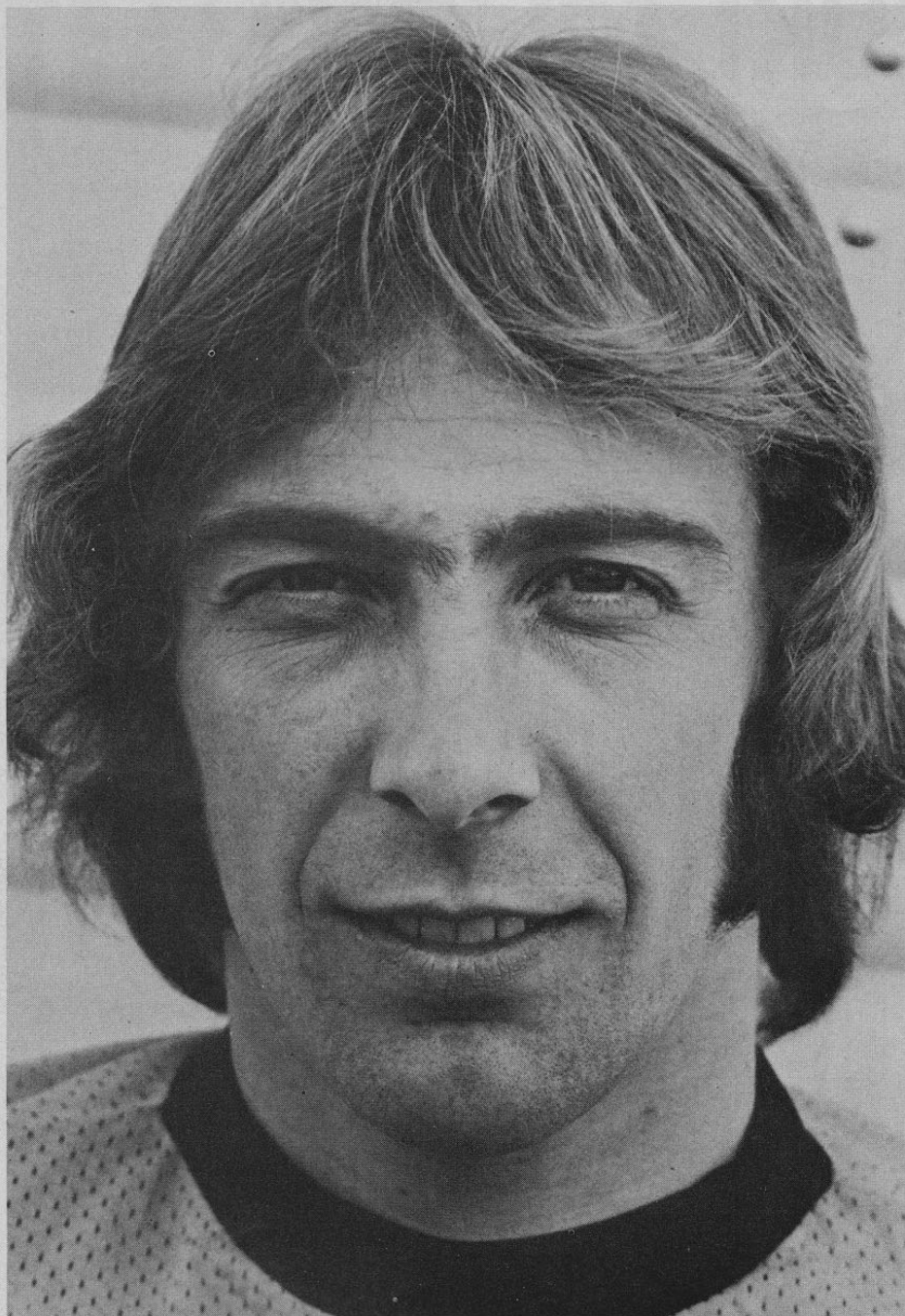

The National 500 class was a dogfight from start to finish, but in the end it was defending National Champion Jim Weinert who took his monoshock Yamaha to the series title and the 1975 crown.

Going into the final race of the five-race series at New Orleans, Billy Grossi had a narrow lead in the standings, followed by Weinert, Steve Stackable and Pierre Karsmakers. Only 30 points separated the four. New Orleans turned out to be a race of crashes and survival (see story, this issue), and Weinert survived the best, finishing (2-4) for the overall victory and the Series title.

Weinert's win gave him his second consecutive Open title, his first with Yamaha. He was the only rider in the series to win more than one overall victory, and he finished out of the top ten only once, in Virginia, where an ignition problem caused him to miss several laps. Weinert's victory in one of the closest title races in AMA history established him as a continuing force in American motocross. III



(Russell photo)

## 1975 500cc CHAMPIONSHIP EVENTS

### BALDWIN, KANSAS - June 8

- 1) JIM WEINERT (1-1) ..... Yamaha
- 2) Gary Semics (3-4) ..... Kawasaki
- 3) Kent Howerton (6-2) ..... Husqvarna

### MEXICO, NEW YORK - August 10

- 1) Pierre Karsmakers (1-2) ..... Honda
- 2) JIM WEINERT (3-1) ..... Yamaha
- 3) Kent Howerton (2-3) ..... Husqvarna

### AXTON, VIRGINIA - August 17

- 1) Brad Lackey (2-3) ..... Husqvarna
- 2) Steve Stackable (1-4) ..... Maico
- 3) Marty Smith (7-1) ..... Honda

### RAVENNA, OHIO - August 24

- 1) Billy Grossi (2-1) ..... Suzuki
- 2) Pierre Karsmakers (3-2) ..... Honda
- 3) Steve Stackable (4-5) ..... Maico

### NEW ORLEANS, LOUISIANA - September 1

- 1) JIM WEINERT (2-4) ..... Yamaha
- 2) Gary Semics (4-3) ..... Kawasaki
- 3) Steve Stackable (7-1) ..... Maico

## 500cc NATIONAL CLASS FINAL STANDINGS

- 1. Jim Weinert, Laguna Beach, CA (480) ... Yamaha
- 2. Steve Stackable, Austin, TX (430) ..... Maico
- 3. Pierre Karsmakers, Mission Viejo, CA (400) Honda
- 4. Billy Grossi, Santa Cruz, CA (359) ..... Suzuki
- 5. Kent Howerton, San Antonio, TX (341) ..... Husqvarna
- 6. Gary Semics, Lisbon, OH (290) ..... Kawasaki
- 7. Brad Lackey, Pinole, CA (200) ..... Husqvarna
- 8. Marty Smith, San Diego, CA (180) ..... Honda
- 9. Terry Clark, Lancaster, CA (83) ..... Husqvarna
- 10. Tony DiStefano, Morrisville, PA (80) ..... Suzuki

# 250 national champion **TONY DISTEFANO,** **TEAM SUZUKI**

The National 250 chase was a battle down to the wire between Tony DiStefano of Suzuki and Kent Howerton of Husqvarna. In the end, it was DiStefano's consistency which was the deciding factor.

Howerton won three of the five National events while DiStefano won only one. But Tony's five-race total of one first, two seconds, one third and one fourth collected 30 more points for him than Kent could manage, and that was the difference.

DiStefano brought the same determination and strength of purpose to the 250 class chase as he did to last year's 500cc class, a class he almost won in his first full year on the National circuit. Considered to be an Open class rider, Tony's victories in the 250 National and the Inter-AMA Series (also 250cc) mark him as America's most consistent quarter-liter racer. At 19, he'll be a star for a long time to come. 

## 250cc NATIONAL CLASS FINAL STANDINGS

1. Tony DiStefano, Morrisville, PA (570) ..... Suzuki
2. Kent Howerton, San Antonio, TX (540) ..... Husqvarna
3. Billy Grossi, Santa Cruz, CA (337) ..... Suzuki
4. Jim Weinert, Laguna Beach, CA (318) ..... Yamaha
5. Jim Ellis, Cobalt, CT (235) ..... Can-Am
6. Mike Runyard, Whittier, CA (220) ..... Can-Am
7. Steve Stackable, Austin, TX (218) ..... Maico
8. Marty Smith, San Diego, CA (137) ..... Honda
9. Gaylon Mosier, Garden Grove, CA (135) ..... Maico
10. John Savitski, Atlas, PA (126) ..... Bultaco

## 1975 250cc CHAMPIONSHIP EVENTS

### PLYMOUTH, CALIFORNIA - April 6

- 1) Kent Howerton (1-1) ..... Husqvarna
- 2) **TONY DISTEFANO** (3-2) ..... Suzuki
- 3) Jim Ellis (2-4) ..... Can-Am

### BRUCETON MILLS, WEST VIRGINIA - May 4

- 1) Jim Weinert (1-2) ..... Yamaha
- 2) Steve Stackable (3-1) ..... Maico
- 3) Billy Grossi (4-3) ..... Suzuki

### NEW CASTLE, KENTUCKY - May 25

- 1) Kent Howerton (2-1) ..... Husqvarna
- 2) Billy Grossi (1-3) ..... Suzuki
- 3) **TONY DISTEFANO** (6-2) ..... Suzuki

### OMAHA, NEBRASKA - June 1

- 1) **TONY DISTEFANO** (2-2) ..... Suzuki
- 2) Jim Ellis (4-3) ..... Can-Am
- 3) Marty Smith (8-1) ..... Honda

### LAKE WHITNEY, TEXAS - June 15

- 1) Kent Howerton (1-1) ..... Husqvarna
- 2) **TONY DISTEFANO** (2-2) ..... Suzuki
- 3) Billy Grossi (6-3) ..... Suzuki

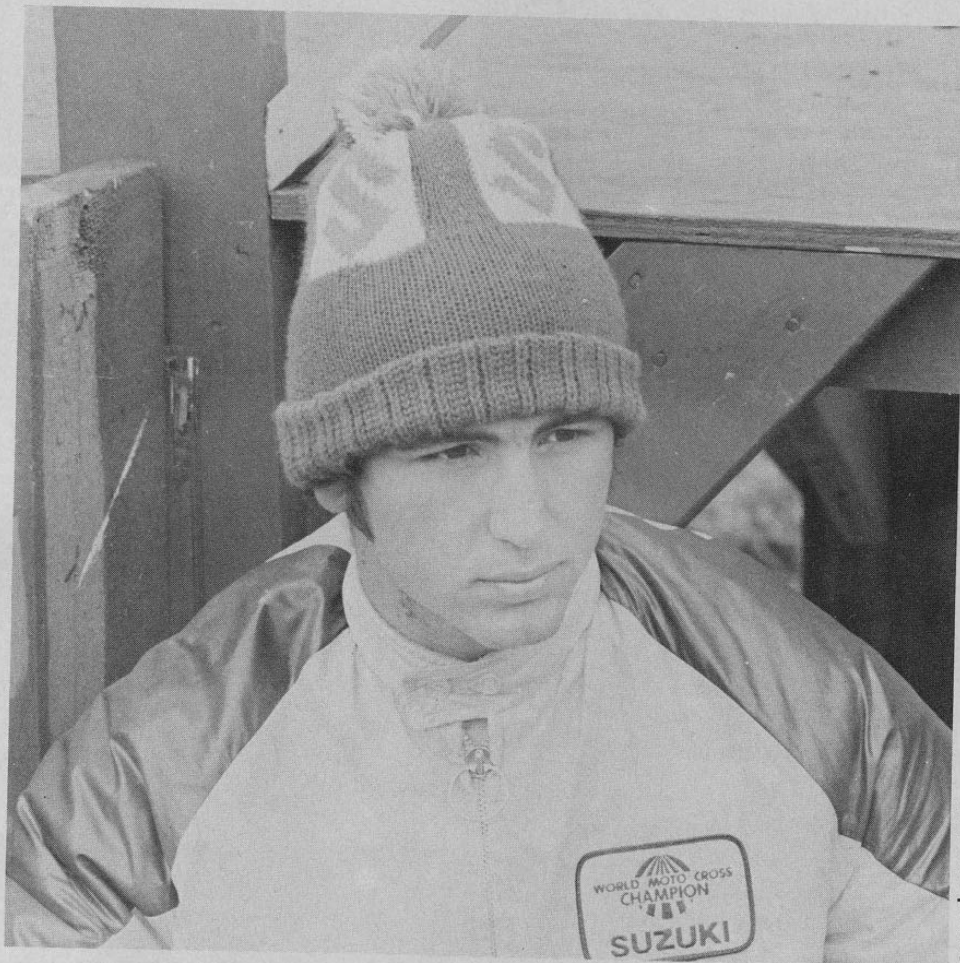

(Russell photo)



# 125 national champion **MARTY SMITH, TEAM HONDA**



(Gianatsis photo)

Tim Hart's initial victory in the mud at Hangtown made it momentarily appear that the race for the 125cc title might be a tight one, but defending champion Marty Smith quickly put an end to that. Smith dominated the National 125 class like no one has ever dominated a National class before, winning 12 consecutive motos in the last six races of the season and amassing 1000 points. Hart, his closest challenger, had 457 points. Smith's mastery of the class was so total that he had clinched his title by the fifth race of the seven-race series.

Midway through his record-breaking year, Marty Smith had the opportunity to compete against the world's best in the first United States 125 Grand Prix. The result was another (1-1) finish, the first time in history that an American has ever won both motos of a Grand Prix event.

Marty Smith is only 18 years old, and he's going to be around a long time. The opposition can only hope that he'll get Grand Prix fever and go to Europe. Until he does, the pickings are likely to be lean in the 125 National class. TT

#### 125cc NATIONAL CLASS FINAL STANDINGS

1. Marty Smith, San Diego, CA (1000) ..... Honda
2. Tim Hart, Torrance, CA (457) ..... Yamaha
3. Dan Turner, Placerville, CA (335) ..... Bultaco
4. Nils-Arne Nilsson, San Diego, CA (330) ..... Husqvarna
5. Bruce McDougal, Orange, CA (285; ..... Yamaha
6. Gary Wise, McAllen, TX (256) ..... Honda
7. Mike Kessler, Farmingdale, NJ (240) ..... Husqvarna
8. Mickey Boone, Winston-Salem, NC (226) ..... Honda
9. Warren Reid, Westminster, CA (223) ..... Honda
10. Tommy Croft, San Diego, CA (210) ..... Honda

#### 1975 125cc CHAMPIONSHIP EVENTS

##### PLYMOUTH, CALIFORNIA - April 6

- 1) Tim Hart (3-1) ..... Yamaha
- 2) Doug Raines (2-4) ..... Kawasaki
- 3) MARTY SMITH (5-2) ..... Honda

##### MIDLAND, MICHIGAN - June 29

- 1) MARTY SMITH (1-1) ..... Honda
- 2) Jim Ellis (2-2) ..... Can-Am
- 3) Mike Kessler (3-3) ..... Husqvarna

##### OMAHA, NEBRASKA - July 13

- 1) MARTY SMITH (1-1) ..... Honda
- 2) Bruce McDougal (9-3) ..... Yamaha
- 3) Jim Turner (7-5) ..... Yamaha

##### DELTA, OHIO - July 27

- 1) MARTY SMITH (1-1) ..... Honda
- 2) Tim Hart (2-2) ..... Yamaha
- 3) Tommy Croft (3-4) ..... Honda

##### BRUCETON MILLS, WEST VIRGINIA - August 3

- 1) MARTY SMITH (1-1) ..... Honda
- 2) Nils-Arne Nilsson (4-3) ..... Husqvarna
- 3) Tommy Croft (2-5) ..... Honda

##### SAN ANTONIO, TEXAS - August 24

- 1) MARTY SMITH (1-1) ..... Honda
- 2) Gary Wise (2-4) ..... Honda
- 3) Dan Turner (6-2) ..... Bultaco

##### NEW ORLEANS, LOUISIANA - September 1

- 1) MARTY SMITH (1-1) ..... Honda
- 2) Dan Turner (2-3) ..... Bultaco
- 3) Nils-Arne Nilsson (4-2) ..... Husqvarna



250 world champion  
**HARRY EVERTS, BELGIUM**  
*Team Puch*



METZELER  
Reifen



EVERS

CHAMPION



Castrol

race test

# CAN-AM 125 MX-2

*Out-of-the-box power and the sturdiness of a small bore buffalo make the MX-2 a tempting choice for the racer who likes to go stock*



A Can-Am holds the world stock class speed record for the 125cc class with a speed of 89.766 mph through the lights at the Bonneville Salt Flats in Utah. That fact alone should suffice to demonstrate the potential of the Can-Am engine and the manufacturer's bias in the direction of racing and performance. Obviously, the Can-Am 125 which set that record was set up differently than the machine you'll find on your local motocross track (it was also a

TNT model, which is rated at less horsepower than the MX-2), but the basic ingredients which gave the record setter its punch are all there.

The 125 MX-2 is an updated version of Can-Am's first motocross offering, the MX-1. And our experience with the new machine leads us to believe that it can be a consistent winner. Out of the box, it is a fast, strong, good-handling package. Above all, it is a fun bike to ride.



Styling is more European in flavor, even if it is made in Canada. Engine is a square 54mm bore and stroke design with rotary valve. They rate it at 24 hp at 9000 rpm. We didn't dyno it, but that seems a shade high.

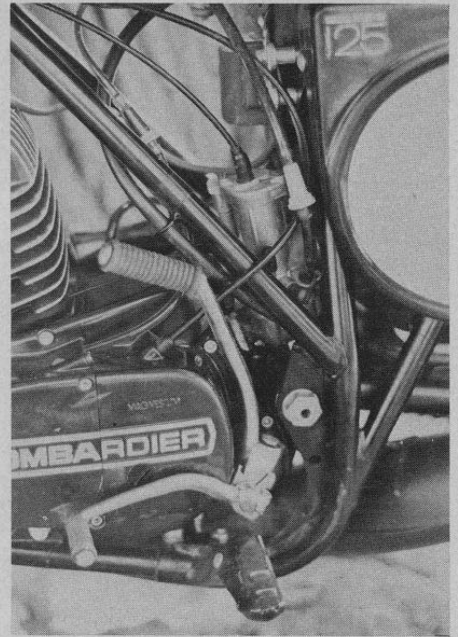

In-gear starts are yours, thanks to primary kickstart. Six-speed gear selection proved to be positive, missed shifts nonexistent.

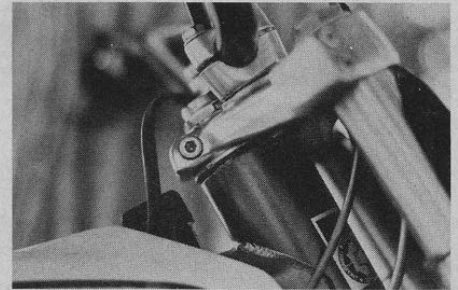

Steering head angle is adjustable by the interchanging of optional cones available from 25 to the stock 31 degrees of rake. Oil injection tank is housed in the top frame tube, with the cap located just below and behind the steering head.

The first Can-Am 125 motocrosser was simply a race bike improvised upon an enduro bike design. It was too heavy, under-suspended and lacked the power of the leader of the class at that time, the 125 Honda. This is no longer the case. The same technology that produced the Salt Flats' record has found its way into all facets of the new MX-2. As a production racer taken off the showroom floor, it is quite competitive. The only real question is whether or not it can be modified to compete with the hot and non-stock semi-factory Hondas, Suzukis and Yamahas which dominate the class today. We know that Can-Am has been spending a lot of time and energy in an attempt at making their team bikes competitive with others in the class, but so far they've been unsuccessful at the big events, even with the likes of Jimmy



# CAN-AM 125MX-2

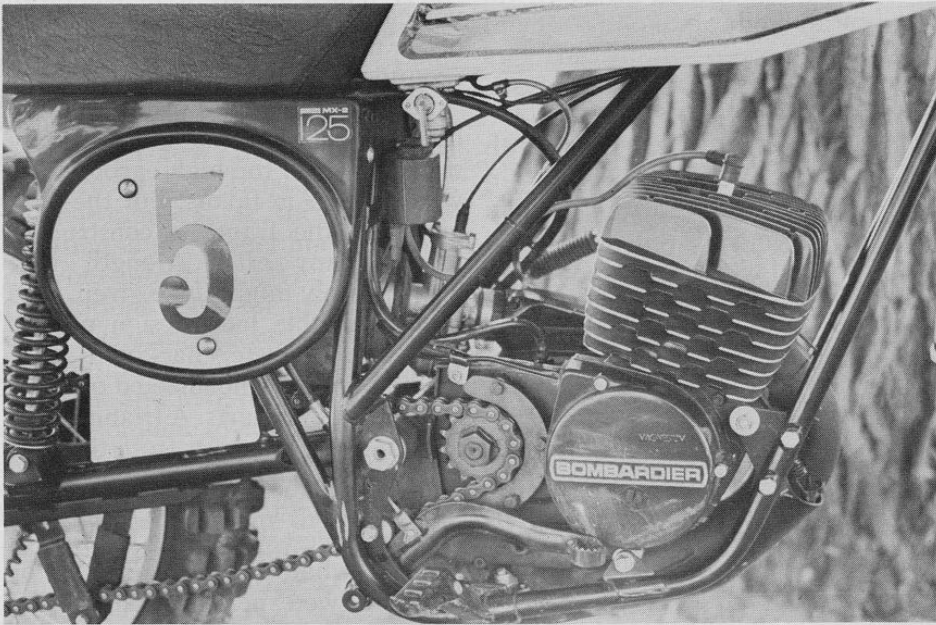

Check out the neat case guard around the countershaft sprocket. Brake is cable-operated and the lever throw is adjustable. Motoplat CDI unit nestles between the frame struts in front of the air box.

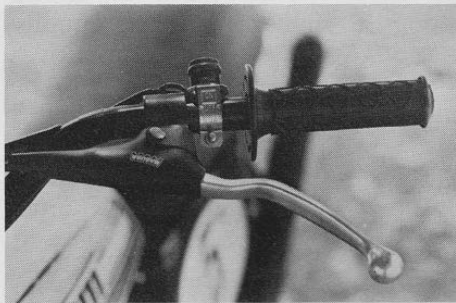

This is an *on/off* switch — don't forget like we kept doing. Waffle grips and Magura Power Levers had good feel.



All that gung on the tank is from the breather caps of the Betor forks, with a little gas thrown in for good measure, courtesy of a poor gas cap gasket.



JANUARY 1976

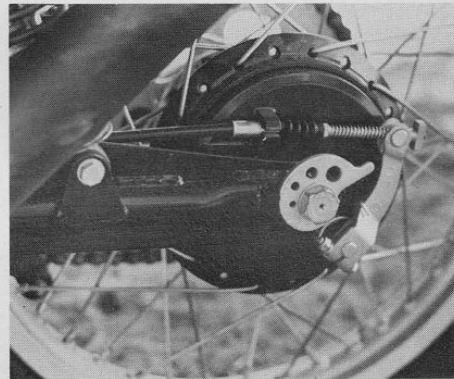

The heavily gusseted swingarm had no noticeable flex. Cam-type chain adjusters are a nice touch. Cable operated brake was pretty sensitive.

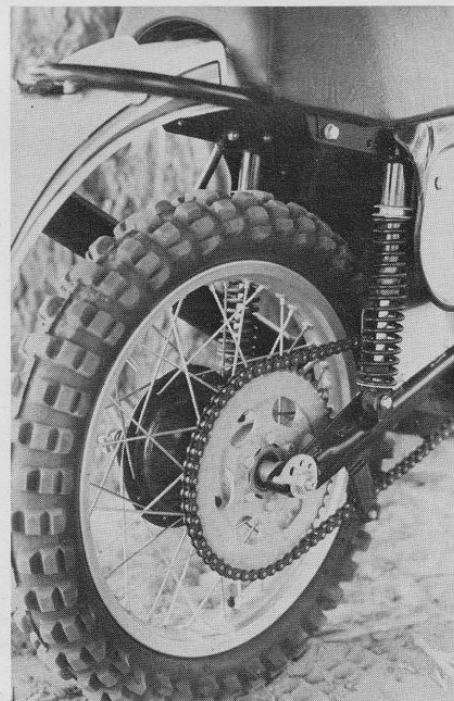

Gas Girlings are fitted to the rear. Pre-load is by the addition of cooling fins. Stock spring is a 75-pounder.

Ellis at the throttle.

Our test bike already had a lot of time on it when we got hold of it, so our impressions are of an obviously non-virginal offering. We will simply have to assume that general maintenance and initial break-in procedures are similar to those for other small-bore racers. Jetting, waterproofing, spoke nipples and air filter operation are items which should be closely watched when breaking in any motorcycle, and the Can-Am for all its durability, is no exception. We experienced an excessive amount of spoke loosening, even though the spokes should have been well-seated by the time we got the bike. The problem was especially evident at the front wheel. For that matter, though, we've been running into this problem with all the bikes we've tested this year, and aren't sure whether we're riding harder or if rim quality has gone downhill generally. We suspect the latter.

There is a definite European flavor to the Can-Am. The square 54mm bore and stroke dimensions of the rotary valve engine remind you of that old European standard, the Sachs. The Can-Am has the same power characteristics, massive cylinder finning, Bing carburetion and stout styling that dominated the class a few years back before the advent of the serious Japanese 125s. But appearance is where these similarities end. The Can-Am MX-2 is an innovative machine, incorporating many new concepts for motocrossers in its class.

Basically, the 125 MX-2 is the little brother of the powerhouse MX-250. And the close identification between the two machines is more than paint deep. The bikes use the same chassis, though the 125 has a slightly shorter swingarm. Engine internals are heavy duty, with the crank riding on three oversize quality bearings. The gearbox is a six-speed, one more than that of the 250, but it is as sure and strong as that of the larger machine. When the differences between the two models are added up, the 125 comes in with simply a smaller engine, an extra gear and (only) about five pounds lighter.

Our test bike weighed 210 pounds with a half-tank of gas. This figure puts it at a disadvantage compared to the competition, as it is giving away 20-30 pounds. Nor could we find many places to trim weight. But

# CAN-AM 125MX-2



this extra weight is used to good advantage, and the strong pulling engine copes with it well, though you can't help wondering how much better the bike could be if it weighed around 180.

Some weight could probably have been saved by using chrome moly steel instead of the high carbon steel which Can-Am favors, but the way in which the frame is constructed matches any extra strength that chrome moly might have given. The tubular double loop design utilizes the large diameter backbone as a holding tank for the injected oil, and holds 2.3 U.S. quarts. A triangulated design, using the struts from the rear section to brace the middle of the chassis, makes the MX-2's frame one of the sturdiest we've ever tested. No matter what the conditions or situation, we experienced absolutely no frame flex.

The heavily gusseted swingarm is another reason for the solid feel of the bike. You have to keep in mind that this same chassis houses the 175 and 250 engines, and is strong enough to make those bikes equally stable. To keep the bike competitively priced, compromises have to be made somewhere, and this standard chassis design is one of them. Even with the savings that using the same chassis for all three models must generate, the MX-2 sells for close to



In a straight line, uphill drag the Can-Am stayed about even with the Elsinore and the RM until third gear. Then the torquey little mutha would wave goodbye.

\$300 more than its competition, but the buyer gets back some of that difference in a frame which is as sturdy as that of any 250 on the market. Depending upon your priorities, that can be a pretty good deal.

The MX-2 is the only serious motocrosser that is currently using oil injection. It is there for the duration of the model line, and will not be modified. We have our reservations about oil injection (call us purists), but it is sort of nice to be able to simply dump straight gas into the tank and take off.

Oil is added to the backbone/oil tank through a large filler tube, with cap and dipstick, just back of the steering head. Despite the size of the hole, you still need a funnel or other improvised device to get the oil in.

Pouring it out of the can just doesn't cut it. But once the tank was topped off we could go through a full day's racing without needing to add oil, and the dipstick makes it easy to check the level if you're in doubt.

Most oil injection systems have the disadvantage of increased throttle pull because of the extra cable needed. Can-Am uses a crank-driven injection pump which meters the amount of oil required by the rpm of the engine, eliminating that problem. As a result, throttle pull is similar to that of non-injection machines.

Another Can-Am innovation is the carburetion of its rotary valve engine. Generally, in a rotary valve setup the carb is tucked in behind a cover plate on the side of the engine

*Cont'd. on page 62*

## SPECIFICATIONS

Make ..... Can-Am  
 Model ..... 125 MX-2  
 Country of Manufacture ..... Canada  
 Retail Price ..... \$1295

### ENGINE:

Type:

Two-stroke, single cylinder,  
 rotary valve

Bore & Stroke ..... 54mm x 54mm  
 Displacement ..... 123.7cc  
 Compression Ratio ..... 15:1  
 Cylinder ..... Aluminum, iron sleeve  
 Carburetion ..... 32mm Bing V-84  
 Ignition ..... Motoplat CDI  
 Lubrication ..... Oil injection  
 Air Filter ..... Oiled foam

### TRANSMISSION:

Type ..... Six-speed  
 Ratios:

- 1) 2.66:1
- 2) 2.07:1
- 3) 1.58:1
- 4) 1.31:1
- 5) 1.09:1
- 6) 0.96:1

Primary ..... Straight-cut gear  
 Drive Chain ..... 520 Diamond

### SUSPENSION:

Front ..... Betor  
 Rear ..... Gas Girling  
 Travel, front ..... 6.75 inches  
 Travel, rear ..... 5.50 inches

### DIMENSIONS:

Wheelbase ..... 55 inches  
 Weight Bias:  
 94/116;  
 45 percent front, 55 percent rear  
 Track Weight ..... 210 pounds

### CAPACITIES:

Fuel ..... 1.9 U.S. gallons  
 Transmission ..... 1.2 U.S. quarts  
 Forks ..... 200cc

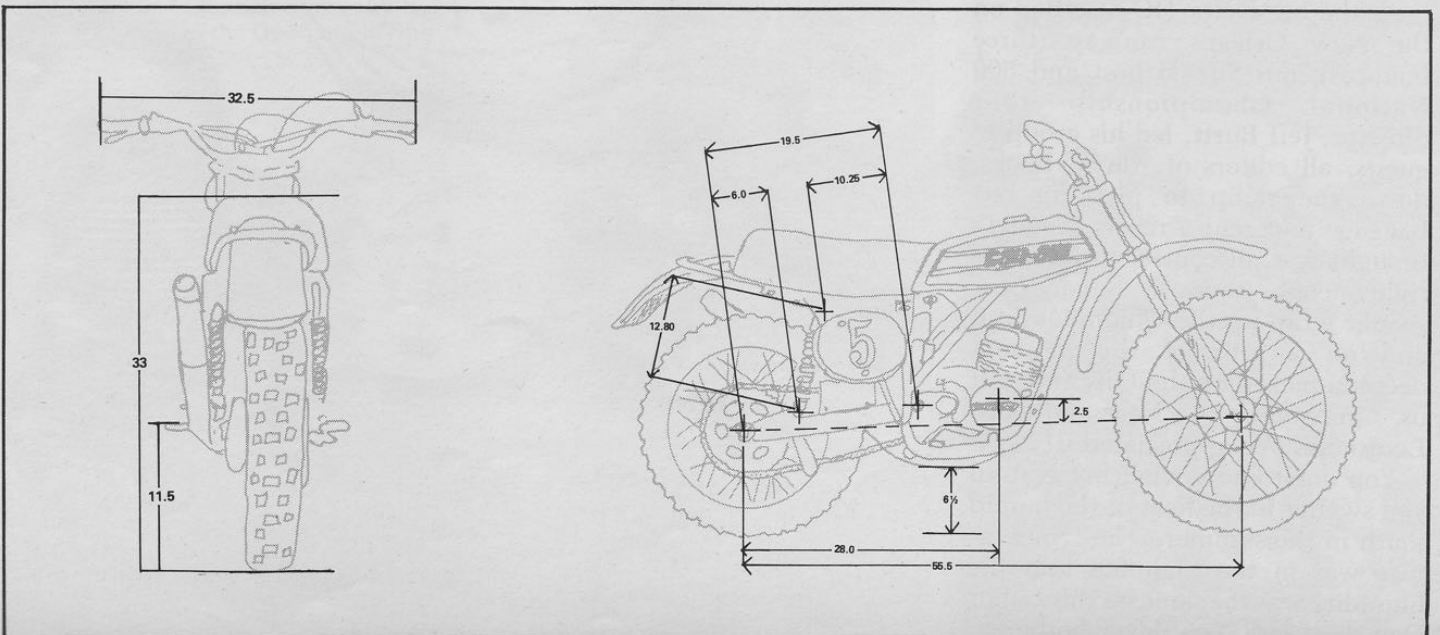

# 500 national **NEW ORLEANS, LOUISIANA**

*You almost needed a flashlight to determine the outcome of one of the most exciting National Championship MX battles in AMA's history*

By Dick Miller

No less than five riders had a shot at winning the 500cc National Championship heading into the last race of the five-race series. "Sugar Bear" Billy Grossi was Suzuki's hope and the leader by a slim 15 points over the defending champion Jim Weinert — who was carrying the Number One plate which he earned last year with a Kawasaki and was now trying for a repeat wearing the yellow and black for Yamaha. Five points back was Maico's Steve "Short Stack" Stackable, the pride of Austin, Texas, and one of the sentimental favorites to take home his first National Championship. The transplanted Dutchman, Pierre Karsmakers, the sole Honda entry, was sitting in fourth position only 30 points off the lead. Kent Howerton, although not really out of it, would need a lot of help from the four guys in front of him plus two very strong finishes if he was to take home the marbles. Potentially he could do it, but he was a definite long shot.

As the big Delta DC-8 settled on the New Orleans runway (three bounces), our Suzuki host and 500 National Championship tour director, Jeff Burtt, led his group of guests, all editors of "dirty" books, down the ramp to pick up our baggage and rent-a-racers. Suzuki's thought was, of course, to have the right people there if Sugar Bear should wrap up the Championship, and on a spur of the moment decision picked up the tabs and sent us, in style, to New Orleans, Louisiana. We appreciated it!

You don't know what hot is until you swelter in the heat of the humid south in the summer. The temperature was in the high 90s and the humidity was the same on this Labor Day weekend. You never bother to



Karsmakers and Lackey's second moto tussle ended with Lackey dropping out with a blown engine, but it didn't end the personal battle these two are waging on and off the track.



turn off the car air conditioner day or night. It seems possible to grab a handful of air and squeeze water out of it, and yet the top big-bore motocross riders in the nation were going to run two 40-minute plus two-lap motos under these conditions. The alligators in the ponds surrounding the track and the adjacent levees of the Mississippi River don't bother to surface unless they have to. It was HOT!

The Motocross West track is a rider's track. It's got everything including a sandy whoop-de-doo section in the back part of the course that saps your energy. Steep drop-offs, straightaway terraced jumps and tight switchbacks with off-camber turns make it a spectator's delight, especially if there's no dust; unfortunately there was. It was impossible for the promoters to keep moisture in the track because of the heat, and it seemed ironic that one of the largest rivers in the world was only a few hundred feet away.

A series of qualifying heats were run to determine a few spots that were open in the big-bore event. Once these were over the first real racing of the day got under way. This was actually a dual National and also the last of the six-event National 125cc Series. Honda's

The Motocross West course had plenty of deep rollers to launch riders sky-high — like Pat Richter in the Open qualifying race.



# NEWORLEANS, LOUISIANA

Marty Smith had long since wrapped up the Championship and he was icing the cake in the last few events. The first moto of this event was no different, as he was never headed in the 40-minute moto. He was looking for his sixth consecutive National in a row and already was in the AMA record books for five.

After a long delay, the first 500 moto got off to a very balky start. Brad Lackey had the holeshot with Billy Grossi in second, but the moto was quickly red-flagged because of a malfunction of the starting gate. This delay caused speculation as to whether there would be time to run the whole program of motos before it got dark. It was already after 4:00 and the first 500 moto was still at the

starting gate.

The re-start had Gary Semics pulling out one of his famous holeshots with a determined Karsmakers right on his tail. Lackey, Weinert, Stackable and Howerton were close behind and the only rider missing who was in contention for the Championship was Grossi. He tangled with another rider a couple of turns after the start and by the end of the first lap was running out of the top 20. Lackey had quickly moved on Karsmakers to take over second as they came around for the second lap, and then on the fourth go-round he put the move on Semics

to take command of the race. Karsmakers couldn't get by Semics and Weinert was pulling both of them. On the ninth lap Jammin' Jimmy passed Pierre for third place and a few laps later took over an undisputed second by taking Semics.

Stackable had been running a close sixth while the leaders were sorting themselves out. Another rider who was running right with him but didn't figure in the race because of recent injuries was Marty Tripes on the Bultaco. They both made their moves at the halfway mark. Tripes moved from fifth to third in two laps, and at the speed he



Those aren't dual speedos on Weinert's bike, they're Kayaba (Red Wing) air/gas reservoirs.



Gary Semics was the early leader in the first 500cc moto but wilted to a fourth by the end of the 40-minute plus two-lap contest. Lackey ran away and hid.



Tony DiStefano had one of his worst days and didn't make the first 20 in the results. When he wasn't doing this . . .



. . . he was doing this.



Mike Kessler (65) was really looking good in the 125 class, but it was another Husky rider, Nils Nilsson, who put two consistent rides together despite a very bad wrist to finish third for the day and fourth in the National standings.

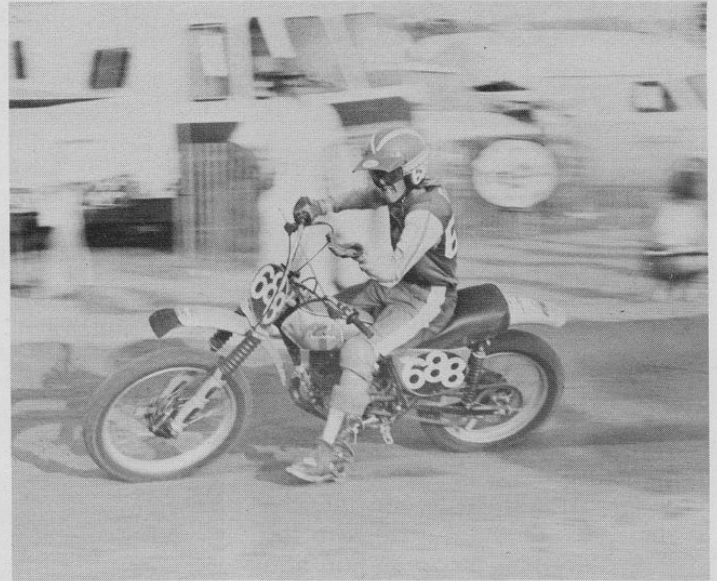

Warren Reid needed a high placing in the final 125 National to break into the top ten standings. His FMF-sponsored Honda beat some pretty heavy company to earn him a fourth for the day and finalize a top ten National number.

was going he looked like he would have second in one more lap. Just as suddenly as his move to the front started, it ended, with him pulling into the pits, dizzy from the heat. Stackable kept his drive going and moved into an undisputed third by passing Semics on the 15th lap, and was quickly followed by a rejuvenated Karsmakers in fourth.

Meanwhile, back in the pack, a lone Suzuki rider was whittling away at the field. Billy Grossi had moved into sixth and was closing, but time was running out. With only a few laps to go and Short Stack closing on Weinert, the crowd started to sense a battle between these two, and as they waited for them to come around on the 22nd

lap, Stackable had dropped to fourth behind Pierre! His rear wheel was disintegrating — a problem not uncommon to Maicos.

With Stackable's bike crippled, Karsmakers', Semics' and Grossi's pit crews urged their riders on and before the checkered fell Stackable was relegated to seventh. Grossi had fought his way through the pack and



Steve Stackable overhauls early leader Gary Semics coming out of the sandpit. "Short Stack" lost the National championship by 50 points when his rear wheel broke apart four laps from the finish of this moto while he was in striking position of a sure second place finish. The difference in points between second and seventh is 80.



Marty Tripes, in his second race since recuperating from a broken collarbone earlier in the year, showed flashes of brilliance plus his usual inconsistency.

# NEWORLEANS, LOUISIANA

finished fifth. Weinert now had the edge with his second place finish going into the final moto, but it was still anybody's race. Lackey was the protagonist, as he had no chance at winning the championship but could possibly take second in the final standings depending on the other riders' results in the next moto.

After another long delay, the final moto of the 125 National got under way. It turned into one of the wildest races of the day. Before the race there had been speculation and finally a riders' meeting to determine how long the final two National motos should go because of the possibility of darkness. All of the riders elected to go the full 40 minutes because of the closeness of the positions that would determine the final outcome of the National Championships.

Marty Smith took over from early leader Danny Turner after a couple of laps, and was soon followed by his factory teammate, Tommy Croft. Halfway through the moto Marty pulled into the Honda pits at the side of the track with clutch trouble and Croft took the lead. As he came by the start straightaway he glanced at

Roy Turner in the Honda pits who was giving him the number one sign. As Croft looked back it was just in time to see a slower rider bobble in front of him and they both went down, with Croft limping off the track with an injured leg. A very fast Mike Kessler on a Husqvarna inherited the lead but was caught on the closing laps by a determined Marty Smith, who came through the pack to pick up his sixth National win in a row. Incredible!

It was now almost seven o'clock and they were still trying to get some



Kent Howerton "takes gas" between motos in the Husqvarna compound. His consistent rides earned him a fifth overall for the day.

moisture into the track for the final 500 moto. Mike DiPrete (DeePreet), the National MX Referee, was concerned. He asked me why it was that I seemed to show up at all the controversial events of the year. He speculated that maybe I was a hex for them. He was only kidding — I think! One thing is certain: DiPrete, Light Brown, Chuck McCall, Tex Meyers and even the feisty starter, Chandler, are doing a bang-up job, and even though they have their problems they are still the class of the AMA monarchy.

With barely 40 minutes of light left in the day and Chuck McCall

*Cont'd. on page 68*

## RESULTS NATIONAL MX, New Orleans, Louisiana

### 500cc CLASS

1. Jim Weinert (2-4)	YAM
2. Gary Semics (4-3)	KAW
3. Steve Stackable (7-1)	MAI
4. Pierre Karsmakers (3-6)	HON
5. Kent Howerton (6-5)	HUS
6. John Savitski (9-8)	BUL
7. Gary Chaplin (8-9)	CZ
8. Trey Jorski (12-11)	KAW
9. Wayne Boyer (15-10)	CZ
10. Mark Blackwell (16-13)	HUS
11. Robert Harris (13-16)	CZ
12. Billy Grossi (5-25)	SUZ
13. Charles Cooper (14-20)	PEN
14. Scott Jordan (19-17)	BUL
15. Johnny Borders (23-15)	BUL
16. Chris Dublin (21-18)	CZ
17. Carl Zortman (10-29)	YAM
18. Terry Clark (34-7)	HUS
19. John Ayers (29-12)	MAI
20. DeWitt Knox (22-19)	YAM

### 125cc CLASS

1. Marty Smith (1-1)	HON
2. Dan Turner (2-3)	BUL
3. Nils-Arne Nilsson (4-2)	HUS
4. Warren Reid (6-4)	HON
5. David Williams (5-7)	YAM
6. Tim Hart (7-6)	YAM
7. Gary Wise (3-11)	HON
8. Jon Leak (8-9)	YAM
9. Bruce McDougal (11-10)	YAM
10. Jack Keese (14-8)	HON
11. Thomas James (13-12)	HON
12. Brad Triana (9-16)	YAM
13. Stephen Gautreau (12-20)	HUS
14. Mike Jones (15-18)	KAW
15. Mickey Boone (29-5)	HON
16. Gary Duncan (17-17)	YAM
17. Phil Alderton (16-21)	HON
18. Mark Gambetta (24-14)	YAM
19. Denny Ashworth (20-19)	YAM
20. Richard Madole (30-13)	YAM

## FINAL AMA NATIONAL MOTOCROSS POINTS

### 500cc CLASS:

1) Jim Weinert, Laguna Beach, CA	480
2) Steve Stackable, Austin, TX	430
3) Pierre Karsmakers, Mission Viejo, CA	400
4) Bill Grossi, Santa Cruz, CA	359
5) Kent Howerton, San Antonio, TX	341
6) Gary Semics, Lisbon, OH	290
7) Brad Lackey, Pinole, CA	200
8) Marty Smith, San Diego, CA	180
9) Terry Clark, Lancaster, CA	83
10) Tony DiStefano, Morrisville, PA	80

### 125cc CLASS:

1) Marty Smith, San Diego, CA	1000
2) Tim Hart, Torrance, CA	457
3) Dan Turner, Placerville, CA	335
4) Nils-Arne Nilsson, San Diego, CA	330
5) Bruce McDougal, Orange, CA	285
6) Gary Wise, McAllen, TX	256
7) Mike Kessler, Farmingdale, NJ	240
8) Mickey Boone, Winston-Salem, NC	226
9) Warren Reid, Westminster, CA	223
10) Tommy Croft, San Diego, CA	210



You can't run a race without official scorers! Ms. DiPrete (black hair) was put to work at her second MX race by the Nat'l MX Referee, Mike DiPrete. Sixteen years old, said the watchful papa.



Marco and Nicolas slouched on the sofa in my Austin, Texas, home. They clutched half-warm bottles of *Cerveza Bohemia* and looked a bit bleary-eyed from their 430-mile drive up from Saltillo, Coahuila, Mexico. Marco planned to race his 125 Yamaha in the annual Austin Aqua-Festival road race through the city's streets the next day; Nicolas was his mechanic, not an enviable task since unseen hoodlums had partially stripped Marco's race bike during a brief stop in Neuvo Leon.

"You want a Mexican beer?" Marco offered. After receiving an enthusiastically affirmative reply, he traipsed out to his VW and returned with a round for everyone. The two Mexicans swilled down the remains of their previous beers and started anew.

"Hey," I kidded, "keep drinking like that and you'll never make it to practice in the morning."

Marco is a serious racer, but wasn't miffed by the insinuation that his heart wasn't totally in tomorrow's activities. "When we come to your country to race, it's just fun. But when we race in Mexico, we race to win. Next week I race in Mexico City, then no beer."

"Funny," I said, "that's what *norte americanos* think about racing in Mexico. Up here we're serious, in Mexico we go for the good time and racing is second."

Talk about Yankees traveling down to Mexico to race is just what

they wanted to hear. The road race was not the sole purpose of their visit. Marco and Nicolas were official representatives of Moto Club Saltillo; their mission was to generate interest among U.S. riders in their annual Gran Premio de la Amistad (translated — Grand Prize of Friendship), two days of short track and motocross. The original intention was a good-natured showdown between Mexican and U.S. riders, but the event is more of a

competition  
**MEXICO'S  
GRAN PREMIO  
de la AMISTAD**

*Is it a race or a party?*

Article and Photos by Pete Szilagyi

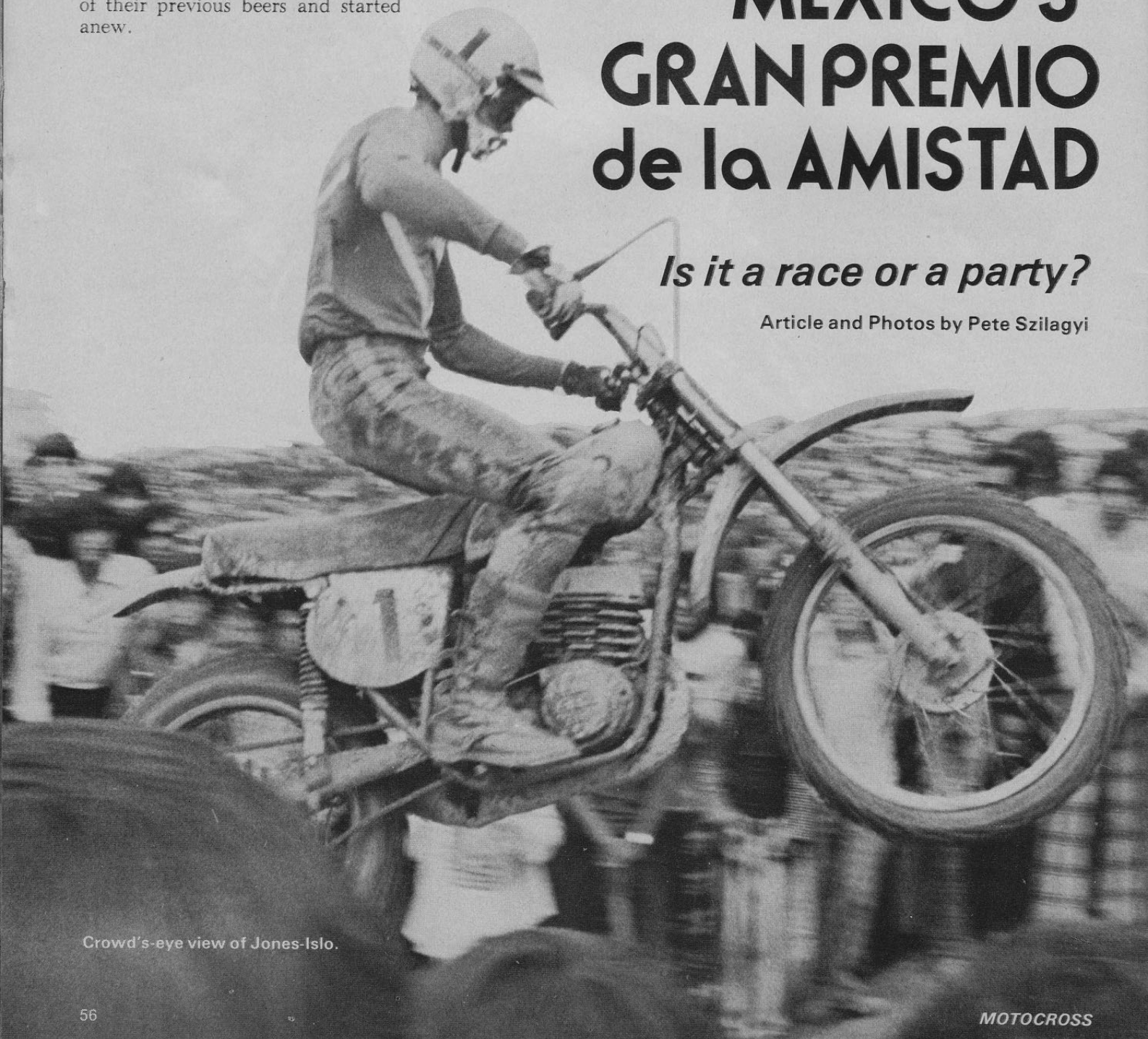

Crowd's-eye view of Jones-Islo.

good-natured hoedown. "Gran Premio," says Nicolas, "is for fun."

Moto Club Saltillo's rider recruitment committee needn't have bothered. Americans show up by the hundreds. The weekend, held in mid-September to jibe with Mexico's *Diez y Seis* independence day celebration, has become an essential date in the itineraries of U.S. racers, as well as those from Mexico, Central America and the Caribbean. Gran Premio is more than a race, it's an adventure. Unless you've fought in Vietnam, survived a plane crash or mingled in a crowd of stampeding

chugging up the Pan American Highway toward Saltillo; stores along the way advertised *pan de pulque*, a bread made from fermented cactus juice. Got your *turistas* medicine ready, gang?

Though I don't expect you to be too interested in the short track doings, they are worthy of mention because they'll give you an idea of how motorcycle racing in Mexico differs from what we're accustomed to. Saltillo's modern *futbol* (soccer) stadium, which seats about 5000 people, has a narrow, clay track about 3/8-mile long extending around the circumference of the playing field. The track is bordered by a four-inch concrete curb, so if a rider wants to take the high line he can use the curb as a berm. Many, many short-trackers bermed off the

curb, but did so quite unintentionally. The occupants of a car from Texas hauling a pair of speedway bikes suffered a severe case of indigestion when they first noticed the curb. They left without even unloading.

Crowd control could have been a big problem. Mexican spectators tend to get much more emotional about the races than their U.S. counterparts. Two years ago at the Gran Premio short track, they poured out of the stands to pummel an American rider who was acting like a fool. He deserved a thrashing, to be sure, but not by 5000 people. This year, to avoid a reenactment, the Mexican Army stationed a couple of dozen soldiers around the

*Cont'd. on page 60*



Talk about your mysterious coincidences — what's the Bazmobile doing in Saltillo?

buffalo, it's liable to be one of the most memorable weekends you'll ever experience. If adventure isn't incentive enough, consider the \$10,000 purse, which is offered by the State of Coahuila, the Moto Club and Moto Islo. The majority of the money always travels northward, but it is amply repaid by all the dollars left behind at hotels, restaurants, markets and liquor stores.

Saltillo could hardly provide a better setting. It is one of the oldest cities in the western hemisphere and fills a 5300-foot high mountain valley, a rival to Colorado's western Rockies for beauty. The air is cool, light and fragrant; this year the arid sage had been soaked by Hurricane Camille, which spent itself in Coahuila. By late afternoon Friday pickups, vans and campers were



# MEXICO'S GRAN PREMIO de la AMISTAD

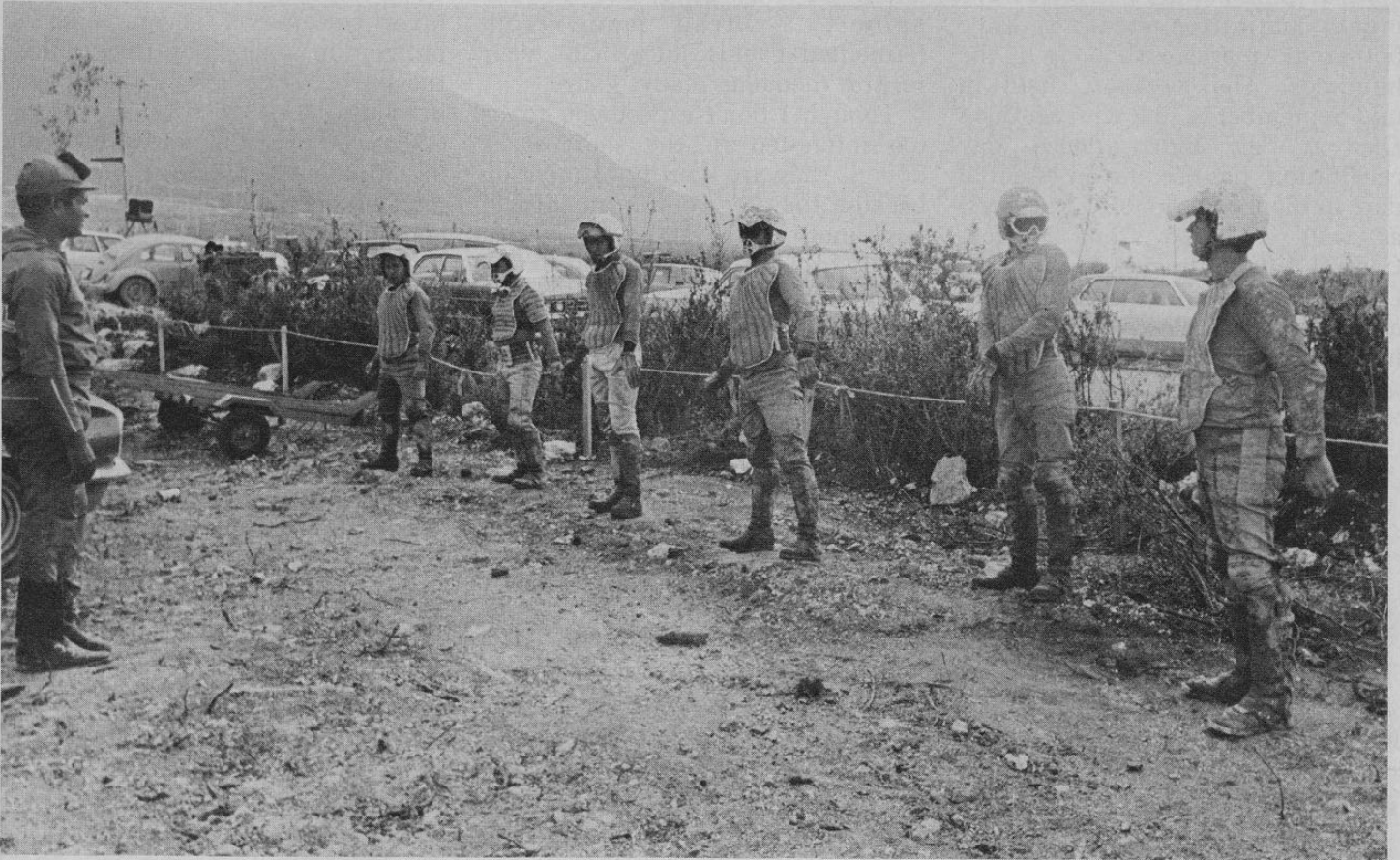

Uno . . . dos . . . tres: Cubans exercising before moto.



Jones (1), Stack (4); leader Wyman Priddy is already long gone.

# DECK THE HILLS WITH RIFLE VOLLEYS

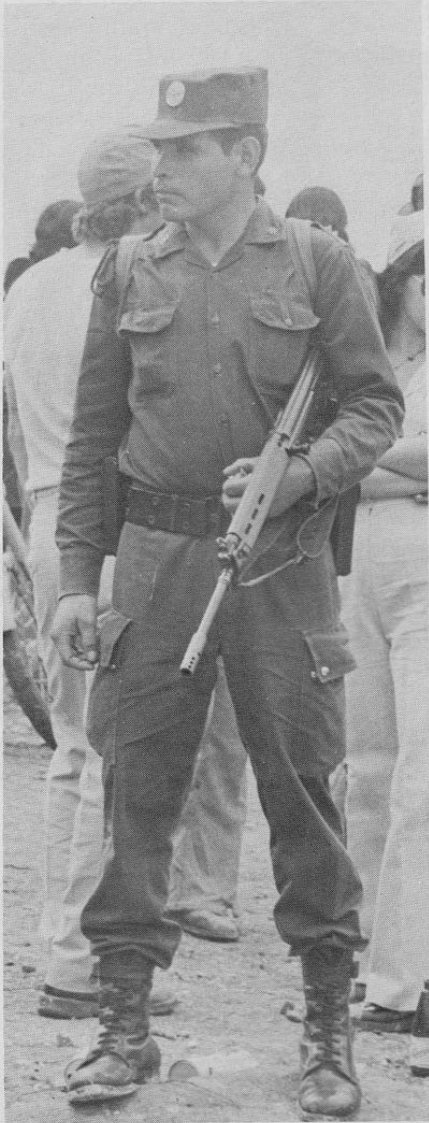

Gran Premio is a laid-back event. Dept. Turismo de Coahuila, the Moto Club and the Mexican Army cooperate to assure that visiting gringos don't get ripped-off, ptomained or cheated out of purse money. But anyone who plans to race in other Mexican motocross events should be aware that it's possible to become involved in some truly bizarre situations.

Take, for example, the plight of three Texas riders who flew way down into the interior of Mexico to participate in the so-called "Mexican International Championship," which was being held in the eastern seaport town of Coatzacoalcos (pronounced-kwatza kwal'kos) in the state of Veracruz. Bill

Kasson, who owns a Yamaha shop, wanted to go down to feel out the area for a possible Steve Stackable-Bill Kasson motocross school, tentatively scheduled for the free time Steve would have after the Trans-AMA series. Jack Hicks, a flamboyant rider who was the subject of several CZ magazine ads a few years ago, and Doug Parks were friends who wanted to go along and ride just for the hell of it. All three live in Austin, and both Kasson and Parks had extensive experience dealing with the Mexican people. Or so they thought.

Mexican motocross tracks range in quality from excellent to aberrations that would make a trials rider flinch; the latter are more numerous. Much to the visitors' surprise, they found the track at Coatzacoalcos to be of truly Grand Prix calibre: grass-covered hills of loose, sandy soil, a challenging layout and well-designed corners. The mood of the spectators and ability of the sponsoring club (the Coatzymoto Cross Club — a perfect name) were, however, somewhat less than professional.



The first 125 Expert moto went well enough. Hicks won it, Kasson third, Parks fourth. During the Amateur races that followed, the situation began to deteriorate. Riders from Guatemala, El Salvador and Mexico (two of whom were nicknamed the Ice Man and the Butcher) attempted to turn the races into a center-punching contest. The spectators got into the act by flinging rocks and beer bottles at the riders. Things settled down long enough to allow Hicks to win the second

125 Expert moto, but when he was crossing the finish line bursts of gunfire broke out in the spectator area. Wisely, Kasson, Hicks and Parks rode to their pits, laid down on the floor of a van and flattened themselves to the thickness of a tortilla.

On the hillside, a major melee had broken out; spectators attacked each other with knives, guns, broken bottles and karate chops. The local police waded into the fight, guns ablaze, and managed to restore at least a semblance of order. Three people had to be carted off to the hospital. According to one onlooker, if the *Federales* had been there instead of the local *policia*, there might have been a substantial death toll. The *Federales* shoot first and ask questions later.

After an extended intermission the races resumed. The 125 Amateurs ran without incident, then the Open Experts rolled to the line for their first moto. Hicks was again on his 125 Monocross. The other riders felt the blondheaded gringo had won enough and were determined to deny Jack another victory. First they ran him into a coconut tree, then into a tall stand of pampas grass. Hicks recovered and began to pass his way to the lead, but after a couple of laps he slid around a corner and slammed into another rider who was "just resting" in the middle of the track.

Jack's riding ability is surpassed only by his implacability. He picked up his Yamaha, straightened everything as best he could and continued the chase. Coming up on the checkered flag he was only a few feet away from the leader, Jose Marin. Hicks WFOed down a steep hill and pulled a full-lock slide through the off-camber turn at the bottom . . . and rode into a crowd of screaming spectators who were so overwrought with the excitement of watching Jack's come-from-behind ride that they were about to begin uprooting trees.

That was just too much. The remaining races were cancelled and the 10,000 spectators were told to go home. Kasson, Hicks and Parks gladly complied. And in case you're wondering, there won't be a Steve Stackable motocross school in Coatzacoalcos this winter. III

# MEXICO'S GRAN PREMIO de la AMISTAD

*Cont'd. from page 57*

stadium; each carried an M-1 rifle. If one of them ordered you to back away from the track and you were slow to respond, he'd simply point his gun at you. Whereupon you'd get the message.

To show their enthusiasm, U.S. sports spectators shout and clap their hands; in Mexico they whistle. When someone crashed, the filled-to-overflowing grandstands and people-laden trees on the east end reverberated with whistling. When a good looking girl crossed the infield, everyone whistled. Both crashes and long-legged honeys were in abundance . . . the place sounded like the aviary at the San Diego Zoo. Though they are emotional and display a tendency toward mass violence, as a group the short track

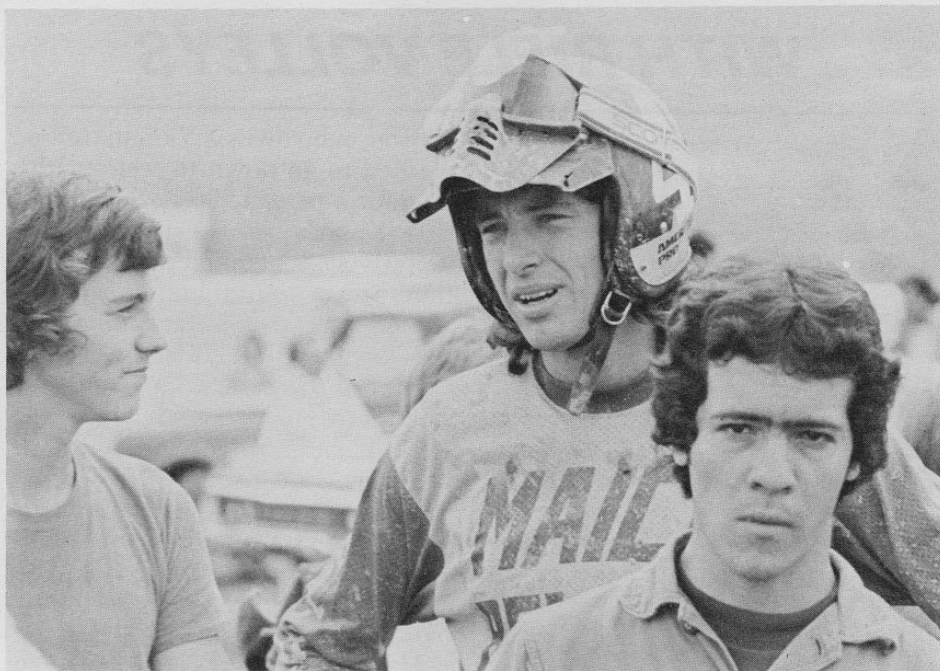

spectators were no more obnoxious than the crowd at a college basketball game.

Both the racing and whistling were brief in duration, however; a black cloud spilled over the mountains and a rainstorm turned the track into a hog wallow during the preliminary heats. The soldiers stayed until the last spectator was gone. Rain dripped from their helmets to their noses to their gun barrels. They slowly sank into ankle-deep mud.

Saturday evening's agenda was highlighted by the Big Mexican Party, an important part of the weekend's revelry which was billed on the race posters in larger type than either the short track or MX. It was held at a large hacienda owned by the Saltillo Ford dealer. There was a grove of 100-foot pecan trees, a swimming pool, waiters dressed in tuxedos and a hundred Americans dressed in jackets advertising everything from STP to Bel-Ray. Drinks and food, of course, on the house. Brandy by the bucket-full: you'd finish a drink and choose from the four fresh ones stacked up in front of

you. By 11 p.m., after the crowd had thinned considerably, the hangers-on each toked on his own bottle of *El Presidente*.

The motocross is one of the most important motor sports events in all of Central America, particularly for Mexico's two-cycle manufacturers, Islo and Carabela. A big win will sell lots of bikes on the domestic market. Each factory takes a different approach to race winning. Carabela didn't bother developing their own competitive race bike. Instead, they painted Yamaha 125 YZs and Maico 250s in their familiar gray and red

color scheme and installed Carabela decals on the gas tanks. Instant racer without all that R&D hassle. Islo is less devious. The factory's 250 MX is a fairly decent machine; it is marketed in this country under the "Cooper" name. A few months back, Islo hired Don and Gary Jones to remake the standard MX into a superbike, which will be called the Jones-Islo. The Jones have produced an admirably trick 250 Jones-Islo prototype and Gary was scheduled to ride it in the Gran Premio MX. Throughout the week preceding the

*Cont'd on page 70*

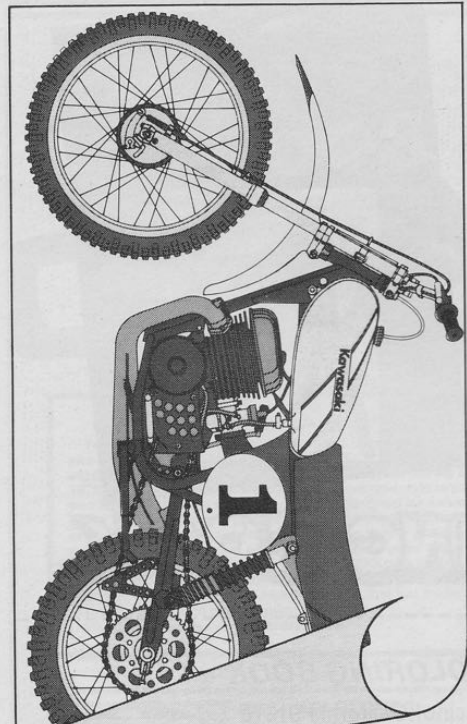

# BIKE ART

NEW FROM BIKE ART

These big, full-color 25" x 38" lithographs of the Kawasaki Z-1 and KX400 are beautifully detailed and ready for hanging or framing. Send \$3.00 plus \$5.00 handling for each poster to "Bike Art," P.O. Box 25922, Los Angeles, California 90025. California residents add \$.18 sales tax. Watch for more dirt and street bikes in this series. MX-1

## smallest lightest fastest MOST EXPENSIVE 125/100cc MOTORCYCLE

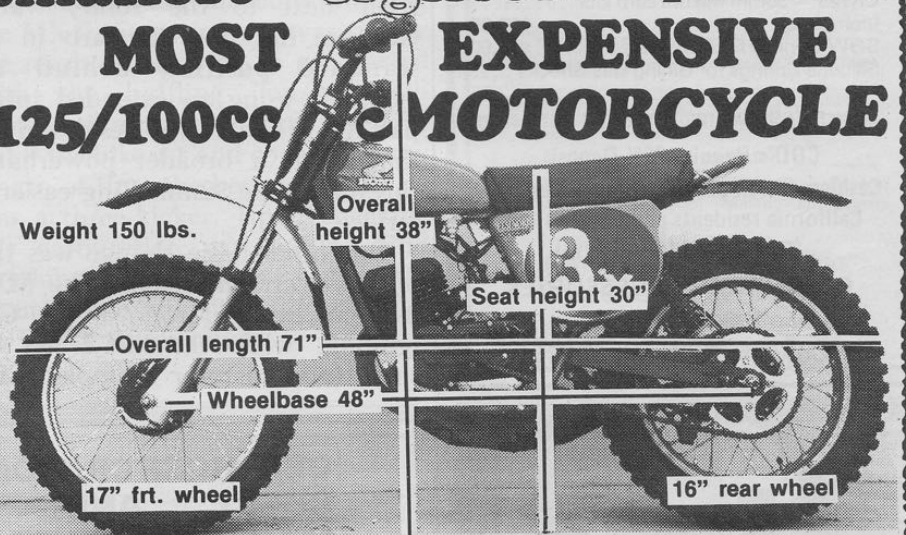

**THE JWRP MINI-EL SINORE 125/100cc IS A LEGAL MOTORCYCLE by special order. around \$2,000**

- smallest - sized for riders not big enough for full-sized machines. Dimensionally a motorcycle, it also fits minicycle rules.
- lightest - 30 lbs. lighter than stock Elsinore.
- fastest - fully-modified CR-125/100cc engine gives best power-to-weight
- most-expensive - we strip an Elsinore, and use parts with a smaller custom frame and quality components. It's expensive. It's a lot of work. But worth it.

Send for JWRP motorcycle stuff. Mini-Elsinore by special order.

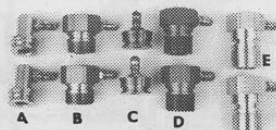

**Air Fork Kits:** Use cushioning effect of compressed air/normal oil dampening. Infinite adjustment. Springs

Check or M/O for \$.....

can be eliminated for weight savings. [A] CR-125, '75-'76 mod.  \$9.95; [B] CR-125, '74  \$13.95; [C] CR-250, '74  \$14.95; [D] CR-250, '75-'76  \$9.95; [E] YZ-125, '75  \$14.95. \*

**New Close-Ratio XR-75**

enclosed. Prices and specs subject to change.

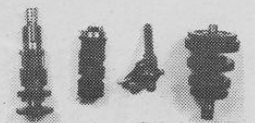

**5-Speed:** Not to be confused with others. This is close ratio MX racing gear cluster, not re-hashed street gearing.  \$149.95.

Name: ..... Address .....  
City: ..... State ..... Zip .....

## JEFF WARD RACING PRODUCTS MX-1

1315 East St. Andrews Place, Santa Ana, Calif. 92705 (714) 546-6923

COMP CROSS ACCESSORIES



**COMP**

**EARLY CHRISTMAS SPECIALS**

- Norstar or Munari Pro Boots .....\$56.95
- American Pro MX Socks (red or yel) ..\$2.75
- Norstar or Munari Super Leathers ...\$76.95
- Bell "RT" Helmets (red or blue) ....\$32.95
- Hallman "New" MX Peaks .....\$2.75
- (R, Bl, W, Yel) .....
- Mikkola 707 Rock Guards .....\$6.75
- 2" wide-Red, White, Blue Tie-Downs ..\$5.95
- Jofa MX Gloves .....\$17.95
- J.D. Shoulder Pads .....\$15.95
- Scott Goggles with Face Shields .....\$15.95
- Girling Gas Shocks (set up w/springs) .....
- (state bushing dia., length & sp. rate) ..\$71.95
- Boge Shocks (includes springs) .....\$49.95
- Smith Goggles-Polaroid - "Trick" ..\$11.95
- CR125 - 30mm Mikuni carb kits .....\$33.95
- (complete) .....
- S&W Springs for Konis .....\$10.00
- Silicone Springs for Girling Gas Shocks .....
- .....\$12.95
- Scott Face Shields (Blu or Wt) .....\$6.25

COD's Require 25% Deposit.

Cashiers Check or M.O. shipped same day.

California residents add 6% sales tax  
(prices good for 60 days)

**COMP CROSS ACCESSORIES**

P.O. Box 1182

Downey, California 90241

**CAN-AM**

*Cont'd. from page 49*



right next to the rotary valve. Can-Am has put the carb in the standard position behind the cylinder, using an extended intake passage to the valve. Besides giving the engine a broader powerband, this makes the 32mm Bing easier to service.

One other basic change was that of the electrical system. The MX-1 used an external rotor Bosch CDI ignition, while the MX-2 has the small internal rotor Motoplat CDI,

much like that used on many of the Japanese bikes. The high rpm characteristics of small bore engines tend to disintegrate cranks with a large flywheel hanging at the end, and to also keep them from revving as fast as the internal rotored units. The new Motoplat solves these problems for Can-Am.

The MX-2 is a high-revving machine. Its power peaks in the 9000-10,000 rpm bracket, but that's not the way it feels when you're riding it. The powerband is somewhat narrow, understandable considering the power the engine puts out. But the saving grace is that when you're off the powerband the engine will still run clean, refusing to load up in the way that other high-performance 125s do.

It is the rotary valve which gives the engine this advantage of smooth performance coupled with high horsepower, but a drawback seems to be the lack of more r's. We found it hard to believe that we were turning 9000-plus because the engine didn't feel as though it was spinning that highly, seeming to flatten out while other bikes were still screaming their insides out. In first

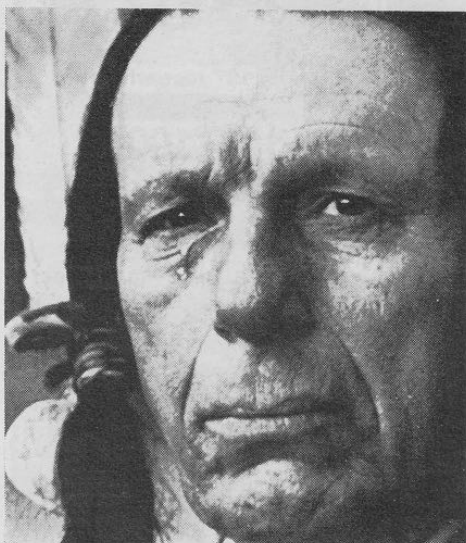

**POLLUTION HURTS ALL OF US. GET INVOLVED NOW.**

You can help by becoming a community volunteer. We'd like to send you the name of the Keep America Beautiful group nearest you. Write:

Keep America Beautiful, Inc.  
99 Park Avenue, New York, New York 10016

**People start pollution. People can stop it.**

**Ad Council** Keep America Beautiful, Inc.



A Public Service of this Magazine & The Advertising Council.

**GET THOSE CRAYONS READY... AND MARKERS... AND COLORED PENCILS!**

**THE GIFT IDEA OF THE YEAR FOR KIDS, FRIENDS AND YOU!**

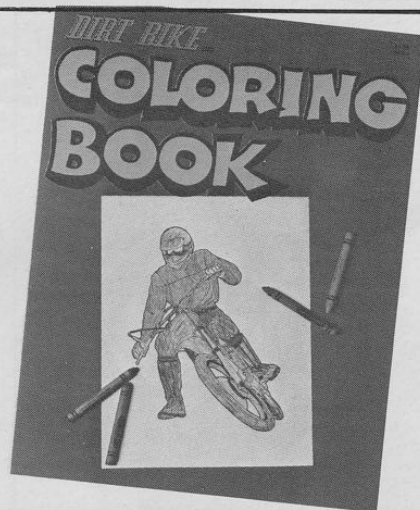

*DIRT BIKE*

**COLORING BOOK**

**BUY ONE  
BUY TWO  
BUY A BUNCH!**

**\$1.50**

Plus \$.50 postage and handling

**DIRT BIKE COLORING BOOK**

MX4-1

P.O. Box 317, Encino, California 91316

Enclose \$1.50 plus \$.50 postage and handling for each copy ordered

Name \_\_\_\_\_

Address \_\_\_\_\_

City \_\_\_\_\_

State \_\_\_\_\_ Zip \_\_\_\_\_

## CUSTOM BOGE/ MULHOLLAND SUSPENSIONS

Write Shock Doctor for your own R

Specify Bike \_\_\_\_\_

Shock Length \_\_\_\_\_

Your Weight \_\_\_\_\_

Mounting Position \_\_\_\_\_

## MIKUNI CARBS

Parts & Tune-up Manual -- 2.95

Chain Bracelets Specify  M  L

Silver --- 3.00 Gold --- 4.75

 Marty Tripes Endorsed  
Gold Belts - All Sizes  
**TRIPES** RACING, INC. 1586 FAYETTE  
EL CAJON, CA. 92020 (714) 448-0670

and second gear you'll really feel the difference when dicing with another hot 125, but as soon as you hit third the Can-Am really begins to shine.

On the starting line of the tough uphill Saddleback course we went off against a stock Elsinore and a ported Suzuki RM time and time again, switching riders to negate any differences. When all things were equal, the Can-Am would begin to pull away when it hit third and fourth. Up until that point it was anyone's race. On smooth, flat starting surfaces, the Can-Am would have to play catch-up in the first 30 feet or so, but it definitely shines under the hard pulling conditions of sandy or muddy tracks.

We had some difficulty starting the MX-2. Sometimes it was simply the result of us trying to get started with the baffling "on/off" kill button still set in the "off" position, but if the bike sat and cooled for any length of time the best we could do was a three-kicker. Upon checking our carburetion we couldn't find anything unusual, so we just had to learn to live with it. After a while, we didn't notice much.

*Continued*

## MOTO-CROSS JERSEYS

For all brands of bikes!  
**NOW IN STOCK!**



Special-made Moto-Cross Jerseys, extra-strong seams, reinforced elbows. Satisfaction guaranteed. Use easy-order form. All orders shipped promptly from stock. Price: **\$9.95**.

Moto-Cross Jerseys ..... \$9.95 each  
70 cents postage and handling

All Brand Names\* and Colors and Sizes. Please send me \_\_\_\_\_ Moto-Cross Jerseys.  
Brand Name\* \_\_\_\_\_  
Size \_\_\_\_\_

(please print)

Name \_\_\_\_\_

Street \_\_\_\_\_

City \_\_\_\_\_

State \_\_\_\_\_ Zip \_\_\_\_\_

\*Enclosed is my check or M.O. for \$ \_\_\_\_\_

\*Honda, Yamaha, Suzuki, Kawasaki, Penton, Can-Am, CZ, Bultaco, Maico, Husqvarna, Indian, Harley-Davidson.

*Div. of Village Togs, Inc.*

**VILLAGE CYCLE SHOP**

11-d Motocross Road

Lake City, Tennessee 37769



# CHAMPIONS

### JT MIKKOLA GLOVE

The glove that is becoming the 1st choice of the top European and American riders! This one — the MIKKOLA MODEL — is an exact replica of the glove that Heikki Mikkola used during the 1975 season. **Made of LAMBSKIN** — this glove conforms to your own hand better each time it is used. It is designed for serviceability by using a second layer of leather and a special stitching process for the palm padding as well as the thumb protection area. The black protective padding on the back gives the protection demanded by the serious rider. The MIKKOLA MODEL is a bright red leather with black protective padding on the back. Each pair carries the same 3 month warranty that has made JT gloves the best buy in racing equipment today! Once again, **JT leads — while others follow.**



### RUSH MY GLOVES!

\_\_\_\_\_ MIKKOLA POSTER — \$3.95  
 pr. MIKKOLAS — Red/Black — \$30.85  YES! Put MY name on the knuckle — \$5.00  
 pr. JT TIBBLINS — Orange/Black/White — \$28.85 (Limit 7 letters) NAME: \_\_\_\_\_

Circle size — S M L XL

Amount Enclosed: \_\_\_\_\_

NAME: \_\_\_\_\_

ADDRESS: \_\_\_\_\_

CITY: \_\_\_\_\_

STATE: \_\_\_\_\_

ZIP: \_\_\_\_\_

BankAmericard  Master Charge  Card No. \_\_\_\_\_ Exp. Date \_\_\_\_\_

California residents include 6% Sales Tax.

**SALES REPRESENTATIVES WANTED!**





## IT'S THE BEST OF RV VAN WORLD

**IT'S DYNAMITE . . . LOTS OF INTERIORS, PAINTS AND VAN HAPPENINGS.**

**ORDER THIS SUPER VAN SPECIAL NOW!**

**\$1.50** plus \$.50 postage and handling

**BEST OF RV VAN WORLD** MX4-1

P.O. Box 317, Encino, California 91316

Enclose \$1.50 plus \$.50 postage and handling for each copy ordered.

Name \_\_\_\_\_

Address \_\_\_\_\_

City \_\_\_\_\_

State \_\_\_\_\_ Zip \_\_\_\_\_

# AHAMAY

anyway you look at it  
**Myerscough Machines are best**

Our line of Yamaha trick parts for the YZ-80 and YZ-125 is extensive...and growing. Some examples are shown here. For more, send for our new catalog.

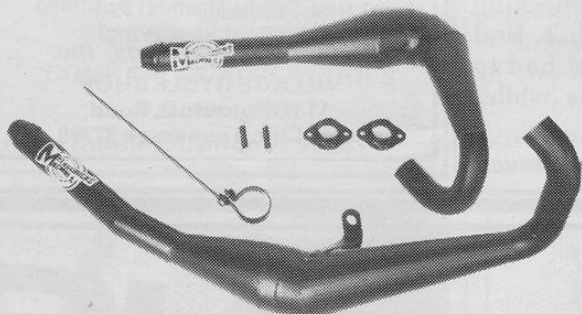

New YZ-125 pipes - Snake up-pipe for instant snap, built to Myerscough specs, \$67.00; torquer down-pipe for smooth power band, \$57.00. All mounting hardware. And, of course, the famous YZ-80 Myerscough pipe, \$57.00.

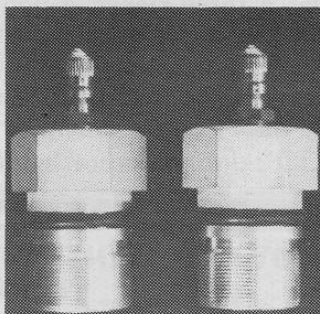

Air/oil front forks-Simple conversion of stock forks with Posi-seal fork caps. YZ-125, \$15.95; YZ-80, \$19.97.

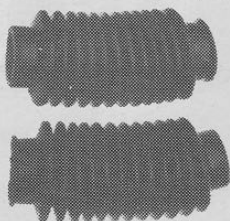

Fork boots-Proven to increase fork-seal life by excluding dirt. Worth their low cost. YZ-80 \$6.95; YZ-125 \$7.95.

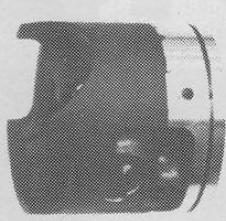

Friction-proofed pistons-Impregnated with friction-reducing compound below rings. YZ-80 \$14.97; YZ-125 \$21.97. Stock, steps one & two.

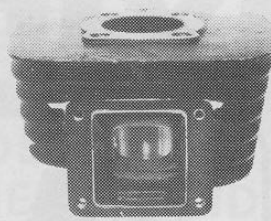

Modified Barrels-MM porting specs [our secret]. YZ-125 \$44.95 [your stock barrel]; YZ-80B \$42.95 [your stock barrel, \$74.97 our barrel].



YZ-80 swing arm bushings-Steel insert inside bronze bushing \$19.97

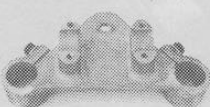

YZ-80 triple clamp-eliminates front fork flexing, \$34.95

\*\*\*\*\* I see my Yamaha your way, send me: \*\*\*\*\*

.....

.....

.....

.....

.....

.....

.....

.....

.....

.....

.....

.....

.....

.....

.....

.....

.....

.....

.....

.....



838 West Colton Ave., Redlands, Calif. 92373  
[714] 793-2473 or 792-2204 MX-1

## CAN-AM

*Continued*

Once the engine is running, it's clean and crisp and will idle easily. The noise from the long bazooka expansion chamber is non-offensive, and can hardly be heard when sitting next to a running RM Suzuki.

Pulling in the clutch is made easy with the use of Magura Power Levers, but the clutch action is somewhat narrow. Off the line you have to be careful of throttle position because of this. The same goes for shifting in turns. This might have been peculiar to our test bike, but whether it was or not, it is easy enough to cope with if you're used to a high rpm race engine. A shifting mistake with most non-rotary valve high rpm engines would have you restarting due to bogging, but the Can-Am's ability to be off the power without bogging makes it no problem.

The MX-2 is outfitted and styled with some nice components. Fenders and gas tank are unbreakable plastic. The tank decal on our test

## TRICK DIST. CO.

### SHOCKS

KONI — \$55.00 w/springs \$65.00  
BOGE — \$47.00 w/springs \$57.00  
(New Rebuildables)  
BOGE w/Reeder Gas springs \$92.00  
BILSTEIN GAS w/springs \$88.95  
GIRLING GAS w/springs \$82.00  
KONI GP Alum. bodies with springs & fluid. \$115.00  
REEDER GAS SPRINGS \$49.00  
Complete—(For Boge, Koni, Bilstein, Yamaha Mono).

### CHRISTMAS SPECIAL

NORSTAR OR MUNARI BOOTS, MATCHING LEATHERS & MX SOX. . . . . \$135.00  
(Pay only \$40.00 now — balance on arrival. Offer void after Jan. 31, 1976).

### NEW

Yamaha 125 Monocross Up-Pipe from Trick Distributing. This pipe looks great & works better than it looks. Comes with everything necessary to make installation a simple bolt-on affair. No power loss, no burnt legs and no smashed pipe . . . . . \$48.95

"TRICK" CR125 UP-PIPE \$48.95  
MUNARI BOOTS \$59.95  
NORSTAR BOOTS \$58.95  
MUNARI MINI CROSS KIDS BOOTS (Sizes 3,4,5,6) \$39.95  
BILL WALTERS LEATHERS \$74.95  
NORSTAR OR MUNARI G.P. LEATHERS \$82.00

### MIKUNI CARBS

VM 26 \$31.00 VM 32 \$37.00 VM 38 \$47.00  
VM 28 \$33.00 VM 34 \$42.00 VM 40 \$62.00  
VM 30 \$35.00 VM 36 \$44.00 VM 44 \$68.00  
Money Order for Full Amount gets items shipped the same day. C.O. D. Orders Require 25% deposit. All Orders Arrive Freight C.O.D. Calif. Residents Add 6% Sales Tax. Mail To:

**TRICK DISTRIBUTING COMPANY**  
2042 BUSH ST.  
SANTA ANA, CA. 92706

unit bubbled and then became obliterated from knee action and gas leakage from a bad gasket seal on the gas cap. This tends to make the bike a little gnarly looking, but no slower. We managed to tweak the fenders, but never to crack or break them, and the Jones chrome moly handlebars withstood several getoffs and slideouts without damage.

The pegs are serrated and spring-loaded, but don't drain as well as they might. The seat is firm, but not uncomfortable, and gives you a good platform for moving around. The tank flows into the seat nicely, and the width is just right for maximum maneuverability.

Front suspension is by Betor, with 6.75 inches of travel, and the rear shocks are Girling gas units with 75-pound springs. Yokohama tires are used front and rear, with the standard 3.00 on the front and a 4.10x18 on the rear. Both are mounted to D.I.D rims. Rear wheel adjustment is made easier with cam-type spacers. The air filter is foam and easily accessible by removing the seat.

The Can-Am is unique in that

there are so many available options for changing the suspension and steering head angles. In the stock configuration the rake is 31 degrees — which is about half a degree more than some of the other hot 125s. The owner's manual (which is really excellent) lists the various cones which are available to change the steering angle from 25 to 31 degrees. We got along just fine with the stock setting. The gas Girlings are pre-loaded by the use of "cooling" spacers. Our bike came with two, and we could have used one more with the stock 75-pound spring.

Spring rates are listed from 100 pounds down to a 45/70 progressive type.

Sorting the suspension on the track proved to be a rewarding but interesting experience. The back end was super, handling the bumps so well you often wondered if you were hitting them. Up front, every time we would slam the front down a shot of fork oil would spray by each side of the startled rider's helmet. By the end of a couple of laps we had just about pumped all the oil out of the tubes through the breather holes in

*Continued*



**CERTIFIED** **Motorcycle & Marine**

**MECHANIC TRAINING**

APPROVED FOR VETERANS

**AMERICAN MOTORCYCLE INSTITUTE**  
**AMERICAN MARINE INSTITUTE**  
 P. O. Box 2628, Daytona Beach, Florida 32015

**1-800-874-0645** TOLL FREE  
 Fla. Res. Call Collect 1-904-255-0295

SEND ME INFORMATION ABOUT:  
 Motorcycle Mechanics Course  
 Outboard Mechanics Course 76-1-21  
 Stern Drive Mechanics Course

Name \_\_\_\_\_ Age \_\_\_\_\_  
 Street \_\_\_\_\_  
 City \_\_\_\_\_  
 State \_\_\_\_\_ Zip \_\_\_\_\_  
 Phone (\_\_\_\_) \_\_\_\_\_ Vet \_\_\_\_\_

## HONDA

### FORK KITS



- SUPERB DAMPING
- BETTER CONTROL
- INCREASED TRAVEL
- NO FINER FIX

KIT NO. H101  
 Honda CR 250  
 XL 250  
 XL 350  
 MT 250

LIST \$2995

(Add \$1.00 for shipping & handling; Calif. residents 6% sales tax)

**FREE CATALOG! WRITE TODAY —**

## YAMAHA

### COMPETITION FORK KIT

- Nearly 9 Inches Travel
- Complete Damping Mod, Including Springs
- Minimum Loss of Engagement

Fits 125 YZC, 250 & 400 CC Monoshock MX & Enduro (1975)

KIT CP9  
**\$3995**

(Add \$1.50 for shipping & handling; Calif. residents 6% sales tax)



Dealer Inquiries Invited

**Number One Products Inc.**  
 8210 So. Sorensen, Santa Fe Springs, Ca. 90670

## MOVING?

Please attach, in this space, the label from a recent issue to insure proper address corrections.

Mail to: **MOTOCROSS ACTION MAGAZINE**  
**Subscription Dept.**  
**P.O. Box 317, Encino, CA 91316**

NEW ADDRESS:  
 Name \_\_\_\_\_  
 Address \_\_\_\_\_  
 City \_\_\_\_\_  
 State \_\_\_\_\_ Zip \_\_\_\_\_



### 38mm CARB ON A 125??!!

**YOU BET!!**

using the **SKUNK WORKS**

**HI-VOLUME INTAKE**

(patent pending)

You won't believe the great increase in low end torque. Also extends your top end; it's like having another gear.

FOR HONDA CR-125, SUZUKI TM & RM-125, TM-100; others available soon.

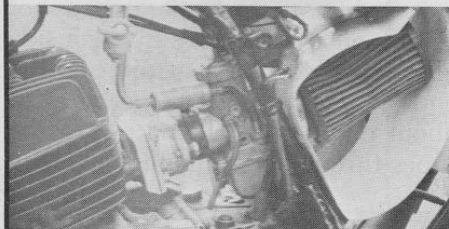

TM 125

A **BOLT-ON** power kit to greatly extend your power band, and increase your total HP. **THIS IS NOT A REED VALVE.**

No cylinder mods are required. Simply bolts on, replacing stock components.

You also get easy starting, and excellent throttle response. Engine also runs cooler.

Kit consists of: 38mm Mikuni	\$ 48.00
K&N Air Filter	8.75
<b>SKUNK WORKS H-V INTAKE</b>	<b>43.50</b>
	<b>100.25</b>

**SPECIAL INTRODUCTORY OFFER:**

\$89.95 + 1.50 S&H (H-V Intake may be ordered by itself for (\$43.50 + \$1.50 S&H)). Florida residents add 4% tax.

**DEALER/DIST. INQUIRIES INVITED**

watch for the latest developments from . . .

**SKUNK WORKS ENGINEERING**

P.O. Box 203-50, DESTIN, FLORIDA 32541

(904) 837-2694

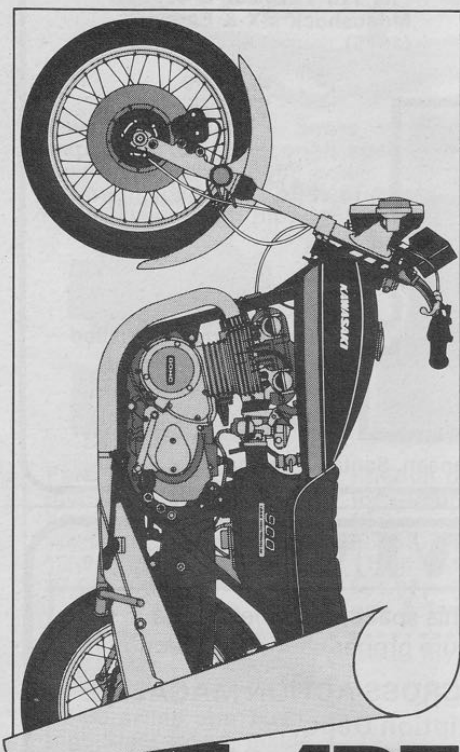

# BIKE ART

**NEW FROM BIKE ART**

These big, full-color 25" x 38" lithographs of the Kawasaki Z-1 and KX400 are beautifully detailed and ready for hanging or framing. Send \$3.00 plus \$.50 handling for each poster to "Bike Art," P.O. Box 25922, Los Angeles, California 90025. California residents add \$.18 sales tax. Watch for more dirt and street bikes in this series.

MX-1

## CAN-AM

*Continued*

the fork caps. Everything was oily, including ourselves.

After taking the caps off and draining what little oil remained, we refilled the legs with 200cc of 30-weight Bel-Ray. The forks no longer spat oil at us, but they still were hydraulic locking on the big hits. We've used Betors before, and although they're notorious for leaky seals and breathers, they usually work quite well. These units didn't. The bad feeling was compounded by the faultless action of the rear. We later found that the fork springs had sacked considerably, and that a 3/4-inch spacer was a big help.

As lousy as the front end was acting, it was still better than those of many bikes on the market. Flicking the bike through the turns and esses was a blast. As you headed for a skatey-type bermshot, a small crank of the handlebars and a twist of the quarter-turn Magura throttle would back the rear end in as neatly as you could ask, and as the rear wheel fought and spun for traction you'd be smoothly on your way to the next turn. After a while you become so confident of the bike's feel that you were throwing it sideways every chance you got, keeping the throttle pegged in the WFO position.

Straightaway handling was also excellent. The strong frame with its minimal flex keeps the bike on its intended line without any sidehop or

pogo-ing action. The faster and harder you push it, the easier it becomes. You find your confidence building more and more as you get dialed into the bike. The front end was the only limit as to how hard and fast you could push it. Had the forks worked better and/or had more travel, we could say that the MX-2 was an extremely good handling machine. As things stand, it's still very good.

The only mechanical problems we encountered were a few broken spokes in the front wheel, due to the excessive loosening we talked about earlier. Shifting was positive, missed shifts nonexistent. The six-speed gearbox seemed to be spaced very closely in first and second, and as a result first was seldom used. Once you hit third the bike really began to pull, and acceleration was outstanding.

You have to shift the MX-2 fairly quickly, as overwinding will lose you a lot of ground to the competition. But under sloppy conditions you should have a big advantage over the radical rpm machines in the class because of the sensitivity and non-loading qualities of the rotary valve carburetion.

In our estimation, the MX-2 is a major improvement over its predecessor. It is now a real motocross machine, a definite threat to the class under the right conditions. It is also a very forgiving bike to ride and a whole lot of fun. And how many potential winners can you say that about?

## THE GREAT AMERICAN PRO MOTOCROSS PANTS

BW

**BILL WALTERS LEATHERS, INC.**

445 South Victory Boulevard  
Burbank, California 91502

**LEATHER** Top grade 3 oz. cowhide—the finest available in 15 beautiful colors.

**LINING** 40 denier nylon tricot—tear resistant yet very pliable and comfortable.

**PADDING** Hip and knee pads are a special high density polyfoam. GP style has plastic knee cups backed with felt pads.

**THREAD** All seams double stitched for double strength with nylon thread.



**PRO STRIPE IS 3" WIDE**

**MOTOCROSS**

MR. RIDER, we stock many hundreds of specialty items for Yamaha, Suzuki, Kawasaki and Honda, plus Husqvarna, Maico, Penton, CZ, and all bikes. If we don't have it on the shelf we will get it fast. A new trick item, \*\*\*. Call on us, we will do our best. Call or write today.

THANK YOU.

10th ANNIVERSARY

# HONDA OF PIQUA

1500 S. MAIN ST., PIQUA, OHIO 45356

TEL. (513) 773-8034 24 hr. RECORD-O-PHONE

## WORKS PIPES

**MOTO-TECH WORKS PIPES**, the pipe with the bright colored tips. A very high quality pipe with a wide power band, yet more horsepower. Each pipe tuned to what each cycle requires for optimum performance. Race proven. The price is also less than most stock pipes.

CAT.#	MAKE	MODEL	STYLE	TIP	PRICE
111	Honda	MR50	UP	Red	\$42.50
112	Honda	SL/XL70	D	Red	\$32.95
113	Honda	XR75	D	Red	\$32.95
114	Honda	SL100/125	D	Red	\$34.95
115	Honda	SL100/125	D	Red	\$34.95
116	Honda	CR125	UP	Red	\$49.95
117	Honda	MT125	UP	Red	\$49.95
118	Honda	MR175	UP	Red	\$49.95
119	Honda	XL250	D	Red	\$39.95
120	Honda	CR250	D	Red	\$59.95
121	Honda	CR250MI	UP	Red	\$64.95
122	Honda	MT250	UP	Red	\$59.95
123	Honda	XL350	D	Red	\$39.95
211	Yamaha	GT80	UP	Yellow	\$42.50
212	Yamaha	YZ80	UP	Yellow	\$42.50
213	Yamaha	100MX A6B	D	Yellow	\$49.95
214	Yamaha	125MX A6B	UP	Yellow	\$49.95
215	Yamaha	AT1 2/3 MX	UP	Yellow	\$49.95
216	Yamaha	YZ125	UP	Yellow	\$49.95
217	Yamaha	YZ125 Mono	UP/D	Yellow	\$49.95
218	Yamaha	DT2 RT2 MX	UP	Yellow	\$59.95
219	Yamaha	YZ250C Mono	UP	Yellow	\$59.95
220	Yamaha	DT2 RT2 End.	UP	Yellow	\$59.95
221	Yamaha	DT3 RT3 MX	UP	Yellow	\$59.95
311	Suzuki	TM100	D	Yellow	\$49.95
312	Suzuki	TS125	D	Yellow	\$49.95
313	Suzuki	TM125	D	Yellow	\$49.95
314	Suzuki	RM125	D	Yellow	\$49.95
315	Suzuki	TS185	UP	Yellow	\$49.95
316	Suzuki	TS250	UP	Yellow	\$59.95
317	Suzuki	TM250	D	Yellow	\$59.95
318	Suzuki	TM400	D	Yellow	\$59.95
411	Kaw	MC1	UP	Green	\$49.95
412	Kaw	F6	UP	Green	\$49.95
413	Kaw	KX125	D	Green	\$49.95
414	Kaw	F11	UP	Green	\$59.95
415	Kaw	KX250	D	Green	\$59.95
416	Kaw	KX450	D	Green	\$59.95
511	Maico	250 Radial	D	White	\$64.95
512	Maico	400 Radial	D	White	\$64.95
513	Maico	450 Radial	D	White	\$64.95

## ALUMINUM SWINGARMS

**U.S. SPORTS Mfg. ORIGINAL** aluminum swingarm. The answer to your handling problems. Strong non-flexing arms with forward or stock shock mounting positions. Guarantee incl. with arms.

#711	YAM 125/175 MX and YZ
#712	HONDA CR125 Elsinore
#713	HONDA CR125 Elsinore
#714	SUZUKI TM125
#715	SUZUKI RM125
#716	KAW KX125
125/175 ARMS 2 position	... \$109.00
250 & UP ARMS 3 position	... \$119.00
#717	YAM All MX & End. 250cc up
#718	HONDA CR250 Elsinore
#719	MAICO All 250 up
#720	CZ all 250 up
#721	SUZUKI 250 up
#722	HUSKY Exc. 125
#723	BULTACO all MX
#724	PENTON All MX
#725	CAN-AM Exc. 125
#726	KAW KX250 up

\*\*\*SPECIFY: MODEL & YEAR\*\*\*  
\*All arms include all necessary hardware and easy instructions. Some come with hollow axles.

## D.I.D. or SUN Rims

D.I.D. .... \$39.95 each  
SUN ..... \$36.95 each  
Specify YEAR — MAKE — MODEL, FRONT — REAR.

## BOOTS MX ISDT

IN STOCK. Specify MX or ISDT and size. One width only available. Half sizes in stock.

FULL BORE ..... \$68.95  
NORSTAR ..... \$66.95  
HI-POINT ..... \$66.95

## 3.5 Gal. BAJA TANK

By Malcolm Smith — light, race proven. COLORS: RED, YELLOW, SILVER, WHITE, or CLEAR. Mounting hardware, GAS CAP included. Specify right or left fuel valve. .... \$44.95

## GOGGLES

Carrera ..... \$11.95  
Scott USA ..... \$12.95  
Malcolm Smith by Scott USA ..... \$11.95

## WHITE OPAQUE FENDERS

### SUZUKI

K-SU1 TM100/125 ft.  
K-SU2 TM100/125 rear  
K-SU3 TM250/400 ft.  
K-SU4 TM250/400 rear  
K-SU5 TS125/185 ft.  
K-SU6 TS125/185 rear

### MAICO

K-MA1 Fr. to early '75  
K-MA2 rear to '75  
M-MA3 Frt. late '75 GP  
M-MA4 rear '75 GP  
N-MA5 GP R/H No. plate  
N-MA7 GP L/H No. plate

### CZ

K-CZ1 CZ all front  
M-CZ2 CZ all rear  
K-CZ3 CZ all mudguard

### HONDA

K-HON1 All front Els.  
M-HON2 125 rear Els.  
M-HON3 250 rear Els.

### KAWASAKI

K-KAW1 KX125 front  
M-KAW2 KX125 rear  
K-KAW3 KX250/450 ft.  
M-KAW4 KX250/450 rear

### HUSQVARNA

K-HU1 125 front  
K-HU2 250 ft. thru '74  
K-HU3 175 '76 GP  
K-HU4 250/360 GP ft.  
K-HU5 Rear to '73 1/2  
K-HU6 Rear all to '74  
K-HU7 Rear '75 GP  
L-HU8 Carb cover to '74  
K-HU9 Mudguard to '75  
M-HU10 Seat base to '74

### PENTON

K-PE1 Front ALL  
M-PE2 Rear All MX

### BULTACO

K-BUL1 Front All MX  
M-BUL2 Rear All MX

### YAMAHA

K-YAM1 Frt. MX '73 on  
K-YAM2 Rear MX '73 on  
M-YAM3 MONO 125 rear  
M-YAM4 MONO 250 up rear

\*\*\*PRICE\*\*\*

K ..... \$9.95  
L ..... \$4.95  
M ..... \$12.95  
N ..... \$6.95

## WORKS SEAT KITS

**WORKS SEAT KITS** incl. special cover, special hi-density foam, adhesive, easy instr. A softer higher seat, cuts fatigue, used by Int. champions.

#610 CR125 ELSINORE  
#611 CR250 ELSINORE  
#612 XR75 HONDA  
#613 HUSKY exc. GP  
#614 HUSKY '75 GP  
#615 MAICO ALL  
#616 PENTON exc. GP  
#617 PENTON late GP  
#618 OSSA PHANTOM  
#619 HODAKA MX  
#620 BULTACO MX  
#621 YZ80 YAMAHA  
#622 YAMAHA MX  
#623 YAMAHA 125 MONO  
#624 YAMAHA 250 MONO UP  
#625 SUZUKI ALL TM MX  
#626 KAWASAKI ALL KX  
#627 CZ ALL MX  
ALL \$17.95 EXCEPT CZ AT \$19.95.

## LEVI MX PANTS

**DYNAMITE** Levi MX pants. Heavily padded. Order waist size only. Adults sizes 28" — 30" — 32" — 34" — 36" — 38". Children's 22" — 24" — 26" — 28".  
ADULTS ..... \$18.95 pair  
CHILDREN'S ..... \$16.95 pair

## NYLON MX PANTS

**MOTO-TECH** super tough, light, comfortable MX pants. Heavily padded with heavy duty zippers and have their own belt. Seat and inner legs are lined for heat protection. A really top value. Order waist size only. ADULTS 26" — 28" — 30" — 32" — 34" — 36" — 38".  
**BLACK WITH YELLOW STRIPE; BLUE WITH STRIPE** ..... \$39.95

## BELL HELMETS

RT "Road & trail," white, orange, red, blue. .... \$36.95  
SUPER MAGNUM silver, white, orange ..... \$49.95  
STAR white, orange ..... \$59.95  
STAR 120 white, orange ..... \$59.95

## PARTS

**PARTS — INSTANT U.P.S. PARTS SERVICE \*\*\* WE CARE \*\*\* HUSQVARNA \*\*\* PENTON \*\*\* MAICO \*\*\* HONDA \*\*\***

## GAS TANKS YZ—CR STYLE

Light, unbreakable plastic gas tanks, YZ Yam or CR Honda style. Incl. gas cap, petcock and all mtg. hdwe. Red, yellow, blue, white colors.  
#911 YAM All 250 up MX, YZ and Mono-shock ..... \$36.95  
#912 HONDA CR125 Elsinore style \$36.95  
#913 HONDA CR250 Elsinore style \$36.95

## GAS SHOCKS

#1011 UPSIDE DOWN KONIS w/ ALUM BODIES, 12.9" and 13.4"; also 11.9" & 13.9" w/bodies ..... \$129.00  
#1012 GAS GIRLINGS 11.8", 12.8", 13.5". Specify Soft, Medium or Hard Dampening ..... \$99.00  
#1013 GAS BILSTEINS 11.9", 12.9", 13.5" ..... \$99.00  
#1014 GAS CERIANI 11.9", 12.9", 13.5" ..... \$99.00  
#1015 GAS MARZOCCHI 12.4", 13.0", 13.5" ..... \$99.00  
#1016 GAS FOX SHOCKS 12", 12.5", 13", 13.5" and 14 1/2" ..... \$99.00  
#1017 KONIS STD. Incl. springs \$69.00  
#1018 BOGE STD. All sizes incl. springs ..... \$59.00  
All prices include springs. Less springs deduct \$9.95.\* When ordering specify make, model, year of bike, also spring rate, length of shock eye to eye, bolt size of eye, weight of rider, etc.

## GAS FORK KITS

**GAS FORK KITS** for all Jap bikes plus many others, converts to air forks, does not include dampening spindles, etc. Inexpensive yet maximum increase in handling. Specify year, make, model of bike ..... \$15.95

**POPPY GAS GORILLA** fork kits incl. special dampening spindles & gas conv. 8" travel. FOR: KAW KX, YAM MX, YZ & MONOSHOCK 250cc UP. Also ALL 250cc UP CZ, SUZUKI and Husqvarna ..... \$45.95

...**POPPY GORILLA FORK KITS** are also avail. Non-gas & incl. special S&W springs for longer travel & special dampening spindles ..... \$45.95

**POPPY MAICO 8" fork kit** (not gas) only ..... \$26.95  
**GAS FOX FORK KITS** for HUSKY, MAICO + more. (FOX FORKS have up to 9" travel; used by LACKEY) ... \$49.95  
1" EXTENDER KITS all bikes, spec. model, etc. .... \$5.95

## UNIVERSAL LEAK-PROOF FORK SEALS

**UNIVERSAL LEAK-PROOF FORK SEALS.** Guaranteed not to leak for one year. FOR ALL BIKES/MODELS ..... \$12.95 kit

## TWIN AIR G.P. FILTERS

**TWIN AIR G.P. FILTERS** — In stock for: YAMAHA, SUZUKI, HONDA, CZ, HUSQVARNA, MAICO, KAWASAKI, OSSA, BULTACO, PENTON, MONTESA\*. SPECIFY: MAKE, MODEL, YEAR, NEW! CAN-AM, AND MORE. FROM \$3.95 to \$22.95. MOST INCLUDE FRAME/2 FOAMS, MONOSHOCK 2 FRAMES/4 FOAMS.

## FOAM FORK LEG PROTECTORS

**FOAM FORK LEG PROTECTORS** — Fit all bikes: Red, Blue, Yellow, Black ... \$3.95 pair

## HALLMAN PRODUCTS

**TEAM JERSEYS:** Husqvarna, Kawasaki, Yamaha, Maico, Bultaco, Suzuki, in factory colors ..... \$18.95  
**EUROPA** style jersey: Yamaha and Penton ..... \$17.95  
**HONDA** style Red/White/Blue ..... \$24.95  
**TEAM LEATHERS:** DeCoster, Pomeroy, Kawasaki, std. GP and Yamaha. Order waist size 28" to 38" ..... \$109.00  
**CROSS PEAKS:** Red, Yellow, Blue, White ..... \$3.25  
**TEAM CHEST PROTECTORS:** Kaw, Honda, Husky, Maico, Suzuki and Yamaha. With factory logos ..... \$19.95  
**JOFA SHOULDER PADS/CHEST PROTECTOR** ..... \$39.95  
**ABH SHOULDER PADS/CHEST PROTECTOR** ..... \$29.95  
\*G.P. FACE ROCKGUARD ..... \$7.95  
\*MX VISOR with FLIP SHIELD ..... \$6.95  
**INTER-AM JERSEY:** Blue, Yellow, Red, Green, great for personalizing; we will silk screen it ..... \$13.95

## HOW TO ORDER

Order sent C.O.D., cash or you may charge to BankAmericard or Master Charge. Personal checks add 10 days to delivery.

How to figure total charges to your door:

Cost of items ordered	\$	
If C.O.D. add	\$	.85
If Ohio resident add 4 1/2 % Tax	\$	
For freight and handling	\$	2.00
Total of Above	\$	

MAIL ORDERS SAVE GAS AND SALES TAX (except Ohio). Prices subject to change.

# MX IS TOUGH!

It's Tough On  
Engines,  
Frames  
And Riders...

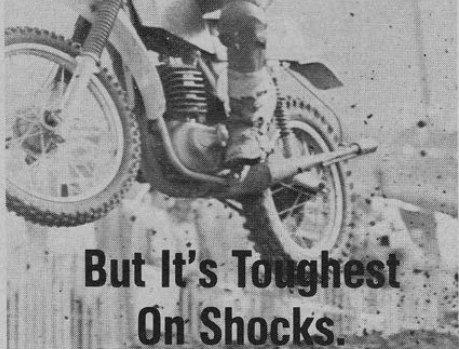

But It's Toughest  
On Shocks.

So S&W  
Developed  
The "STROKER"

The Freon Cell Shock  
Tough Enough To  
Take It!

Elimination of oil  
foaming

Elimination of  
cavitation

Prolonged  
shock life

Six stage valving—  
three valves in  
rebound and three  
in compression.

All the advantages of  
a gas-oil shock at a  
price you can afford.



the "STROKER"  
from



by Monroe

Ask your dealer

or write:

S&W Engineered Products  
Dept. Z-D  
P.O. Box 767  
Downey, CA 90241

## NEW ORLEANS

*Cont'd. from page 53*

stationed in the back shady sections of the track ready to call the race because of darkness, the starting gate fell under the final charge of the 40-rider field. Howerton had a short lead over Karsmakers off the line into the first turn, only to be passed two turns later by Pierre. Stackable, Lackey, Semics and DiStefano were in close pursuit with barely a bike length between all of them. Incredible as it may seem, Grossi had a rider fall in front of him leading into the second lap, putting him into the fence and out of contention for the National Championship.

Karsmakers was now in an excellent position to take home all the marbles, but he would have to keep Weinert behind him. Lackey was now moving on Pierre and had pulled even with him as they exited the turn heading into the pit straightaway of the second lap. They were inches apart, but never touched as the Husky pulled away from the Honda. Karsmakers was visibly upset and shook his fist at Lackey as they rocketed down the straightaway. He later contended that Bad Brad had purposely cut him off and had tried to force him into the fence as they came out of the start/finish turn. There were bad feelings between the two going into the race because of incidents which happened the week before in Ohio. To further

complicate matters, Pierre and DiStefano collided shortly after, while going over one of the many jumps, with both riders going down. Pierre rode a lap with his front brake cable broken and dangling and had to pull to the side of the course to have it cut off. Without a front brake on this course, you were out of contention.

Stackable had moved into an undisputed second behind Lackey, with Semics, Weinert, Karsmakers and a revived Marty Tripes following. At the halfway point, with the sun rapidly disappearing, Brad Lackey's Husky slowed and sputtered to a halt on the back sandy section of the course. His engine had choked to death on the Louisiana dust which had passed through his stock filter. Stackable now had the lead and Weinert had the 500 National Championship as long as he held position on Karsmakers and kept close to Stackable. Tripes, making it look very easy, put a move on everybody, pulled up to Stackable and then passed him. The crowd was going berserk. Stackable had the lead back with two laps to go, and Semics had passed Weinert to move him back to fourth, but it was still enough for Jim. Weinert backed into the National Championship without winning a moto. Stackable's destroyed wheel in the closing laps of the first moto was expensive indeed! The fortunes of racing had given Jammin' Jimmy his second consecutive National Championship. That's racin'.

## HOLIDAY OFFER

HOW TO WIN  
AT RACING

REGULAR PRICE — \$5.00

NOW ONLY \$2.50

SAVE 50%

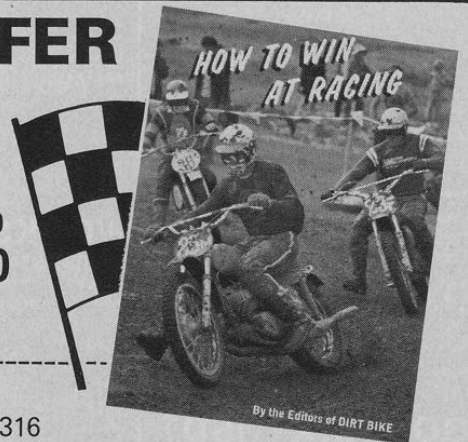

HOW TO WIN AT RACING

P.O. Box 317, Encino, California 91316

Enclose \$2.50 plus 50 cents postage for each copy ordered.

MX-4-1

Name \_\_\_\_\_  
Address \_\_\_\_\_  
City \_\_\_\_\_  
State \_\_\_\_\_ Zip \_\_\_\_\_

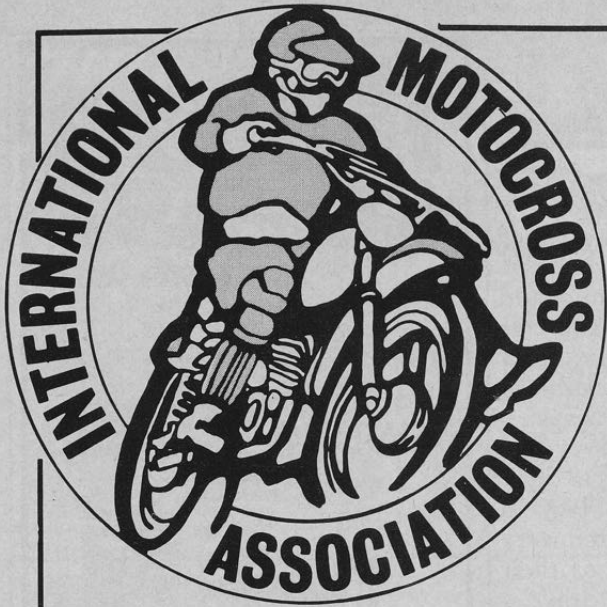

**EVERYONE'S  
DOING IT . . .  
. . . joining the  
*INTERNATIONAL  
MOTOCROSS  
ASSOCIATION***

*This exciting new in-group is open to all dirt riding enthusiasts and it's easy to join.*

**ONLY  
\$800  
PER  
YEAR**

As a member of the International Motocross Association you will receive your membership card . . . with your own sanctioned IMA number that you can wear when racing; a colorful, embroidered patch to sew on your jacket, racing jersey or jeans; an official IMA sticker to put on your bike, pick-up or van; a key chain with the official IMA emblem and a monthly newsletter to keep you up on all the dirt and motocrossing happenings.

We are planning to hold regional drawings to send IMA members to top motocross races, all expenses paid. We will also have available official IMA T-shirts, racing jerseys, beer mugs, coffee cups, belt buckles and many other items.

**Join now . . . encourage your friends to join. Start a racing club . . . future plans include sponsorship of regional motocross races.**



**INTERNATIONAL MOTOCROSS ASSOCIATION**

P.O. Box 143, Encino, California 91316

*I am turned on . . . please enroll me as a member of the International Motocross Association. I have enclosed my \$8.00 membership fee.*

Name \_\_\_\_\_  
Address \_\_\_\_\_  
City \_\_\_\_\_  
State \_\_\_\_\_ Zip \_\_\_\_\_

MX-4-1



# THE ALL-NEW DIRT BIKE PHOTO ALBUM



Filled with action-packed contest-winning photos.

ALSO TIPS ON HOW TO TAKE MOTO PHOTOS

ORDER NOW! \$2 plus \$.50 postage and handling.

## DIRT BIKE PHOTO ALBUM

P.O. Box 317, Encino, CA 91316

Enclose \$2 plus \$.50 postage and handling for each copy ordered

Name \_\_\_\_\_ MX4-1  
 Address \_\_\_\_\_  
 City \_\_\_\_\_  
 State \_\_\_\_\_ Zip \_\_\_\_\_

## MEXICO

Cont'd. from page 61

race, Mexican newspapers ballyhooed Gary as *el piloto fabuloso*.

Trouble was, Islo knew that Steve Stackable and his Maicos would be coming down to Gran Premio and there was a fair chance that he would beat Gary and the fancy new Jones-Islo. In addition, Stackable is immensely popular with the Mexican fans. Last year he beat Wyman Priddy, who is considered a deity second only to the Virgin Mary in northern Mexico. Islo wanted very badly to put Steve on one of their bikes. Stackable, however, drove a hard bargain. He needed traveling expenses for his entourage, which included brother Rolf, sisters Kay and Cass and his mechanic, Bernie Thompson, as well as spending money and a guaranteed first place purse, in case the bikes weren't fast enough to win. Islo blanched and passed on the deal.

At 9 a.m. racers from all over the Americas descended on Lomas de Lourdes, a housing subdivision

Continued

# DIRT BIKE HOW TO GO FAST tech manual

2nd BIG PRINTING

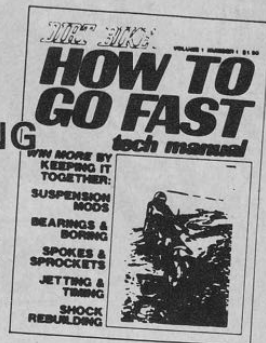

STILL ONLY \$1.50

HOW TO GO FAST MX-4-1  
 Box 317, Encino, Calif. 91316

Please send \_\_\_\_\_ copy(ies) of HOW TO GO FAST. Enclosed is \$1.50 plus 50¢ postage and handling for each copy.

Name \_\_\_\_\_  
 Address \_\_\_\_\_  
 City \_\_\_\_\_  
 State \_\_\_\_\_ Zip \_\_\_\_\_

Dealer inquiries invited.

HOW TO WIN AT RACING—\$5.00  
 All the inside info on how to condition yourself to be a winner... and much more!

DIRT BIKE BUYER'S GUIDE—\$2.00  
 A complete and detailed guide to all the equipment and accessories necessary to be "in" as a rider.

# The Exciting Specials You've Asked For...



DIRT BIKE SPECIALS P.O. Box 317, Encino, California 91316

Please check the publication you want to order and the quantity. Be sure to enclose the proper amount of money. Add 50 cents postage and handling for each copy ordered.

NAME \_\_\_\_\_  
 ADDRESS \_\_\_\_\_  
 CITY \_\_\_\_\_  
 STATE \_\_\_\_\_ ZIP \_\_\_\_\_

- MX-4-1
- CRASH AND BURN SPECIAL
  - MOTORCYCLE RIDER'S GUIDE
  - DIRT BIKE BUYER'S GUIDE
  - FOOFARAW
  - 125cc TESTS
  - MXA TRANS-AMA
  - HOW TO WIN AT RACING

CRASH AND BURN SPECIAL—\$1.50  
 Astounding! Gruesome! Bizarre! 100 pages of the wildest pucker-power photos in existence.

FOOFARAW—\$1.49  
 The Best of DIRT BIKE FOOF! Irrelevant absurdity with cartoons. It's Great!

125cc TESTS—\$1.50  
 The hottest tests on the hottest bike trip around... Carabela, Hodaka, Penton, Suzuki and all the rest.

MOTORCYCLE RIDER'S GUIDE  
 Special all Honda issue... complete with road tests, tune-up and specifications on all Honda models.

MXA TRANS-AMA—\$1.50  
 The photo-action story of the Trans-AMA. All the excitement and thrills of the big races.

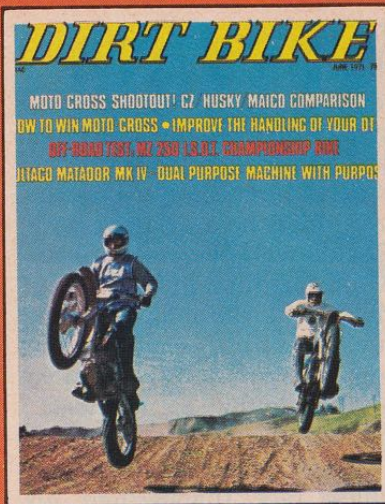

1. 1st ISSUE OF DIRT BIKE

# DIRT BIKE COLOR ACTION POSTERS

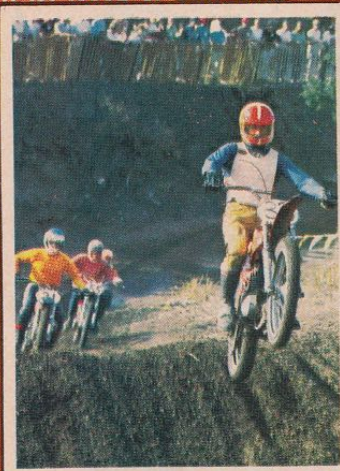

2. ACTION AT THE INTER-AM

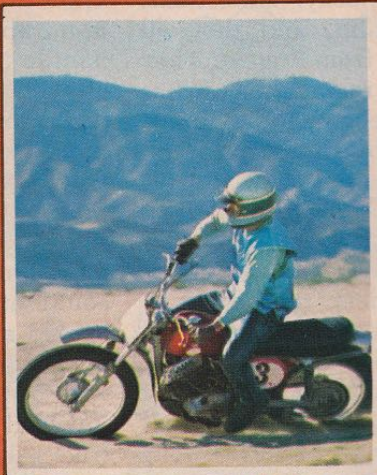

3. JIM CONNOLLY INDIAN DUNES



4. JUNIOR ACTION

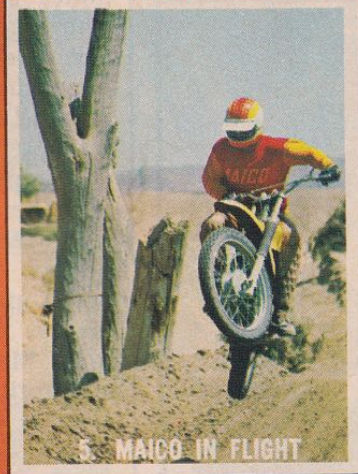

5. MAICO IN FLIGHT

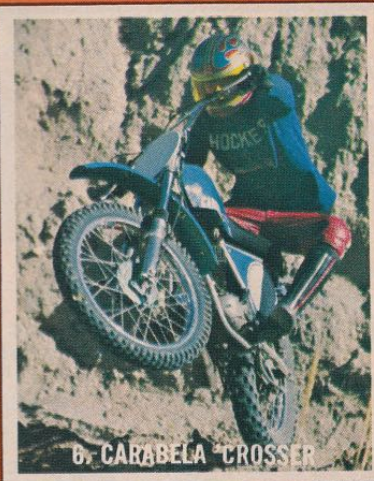

6. CARABELA CROSSER

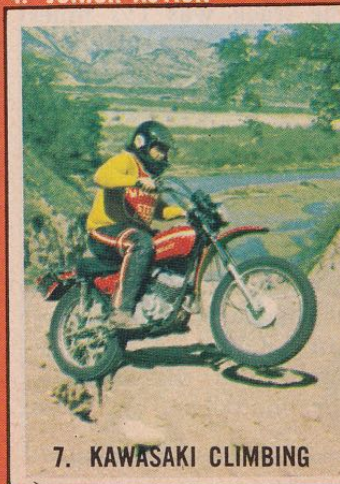

7. KAWASAKI CLIMBING

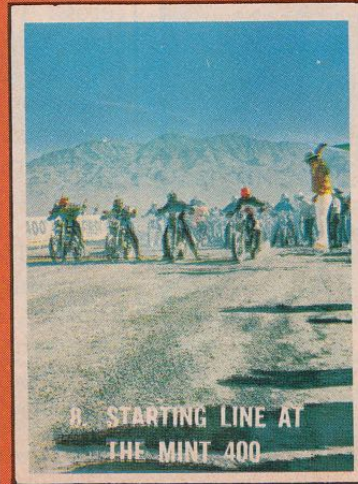

8. STARTING LINE AT THE MINT 400

Got a section of wall that measures 17 x 22 inches? Any old wall will do. Now, here's how to make that wall worth looking at. Hang up one or more of these far-out, blow-mind, trick action posters. The cost? It's right. Just \$2.50 each (plus 25¢ postage and handling), \$7.50 for any four posters that catch your eye (plus a half a buck for postage and handling). Or go all the way and do up an entire room — \$14.00 will get you all eight (of course that same 50¢ added for postage and handling). Order now — that empty wall can't be that interesting to look at.

## PLUS PRODUCTS, INC.

MX-4-1

P.O. Box 14945  
Las Vegas, Nevada 89114

Enclosed is check or money order for \$\_\_\_\_\_.

Poster No. 1.  2.  3.  4.  5.  6.  7.  8.

\$ 2.50 ea. plus 25¢ postage

\$ 7.50 any four plus 50¢ postage

\$14.00 any eight plus 50¢ postage

Name \_\_\_\_\_

Address \_\_\_\_\_

City \_\_\_\_\_

State \_\_\_\_\_ Zip \_\_\_\_\_

# DIRT BIKE

MAGAZINE

Okay, you all know that a bright colored, vented DIRT BIKE racing jersey is a desirable unit. You've seen Ake win the '72 Trans-AMA one. You've seen John DeSoto wearing one in the '73 Trans-AMA. But you couldn't get one, could you? Well, nobody could. Those were special factory prototypes. Now we have them. Regular replicas, even better than the prototypes cause these have the reinforced elbows and the DIRT BIKE logo on both sides. Get your DIRT BIKE Racin' Jersey now, while they last.

**Racin' jersey**

\$14.95 + 50¢ postage and handling. Please send me \_\_\_\_\_ Racin' Jersey (s) S M L XL Enclosed is \$ \_\_\_\_\_ check or money order

BLUE  YELLOW  RED

DIRT BIKE RACIN' JERSEY MX-4-1  
P.O. Box 14945 Las Vegas, Nev. 89114

NAME \_\_\_\_\_  
STREET \_\_\_\_\_  
CITY \_\_\_\_\_  
STATE \_\_\_\_\_ ZIP \_\_\_\_\_

## MEXICO

*Continued*

without houses where the track was located. Among the statesiders were Wyman Priddy and Gary Wise, both of whom are capable of making Jones and Stack work for their money. Also, in a somewhat surprising and historic mainland visit, the Cuban National MX team made an appearance. Except for their two black coaches and distinctively Spanish visages, the Cuban team could easily have been mistaken for Czechs or Russians. All the riders were stocky, almost fat, like Miroslav Halm, and they all rode CZs straight from Prague. They were a highly regimented team, exercising between motos to a cadence barked by the coach (who was dressed in a bright purple jumpsuit with "Cuba" embroidered on the back), and working on their CZs according to a rigid, memorized schedule. Per orders, they spoke to no one. I attempted to converse with the riders, but they waved me over to the coach, who I found to be a jolly, garrulous fellow. Most dismaying was the fact that he spoke

no English, but rattled off Spanish so quickly that only a native could understand him. After a few minutes I managed to find out that the team had either 25 bikes and 20 riders or 20 bikes and 25 riders, and that the half-dozen riders he'd brought with him to Saltillo were the cream of the crop. After the first moto, it was apparent that he must have meant that they were the cream of the crash and burn specialists. Must've been the altitude that got to them.

Before we get into the actual racing, I should mention an unscheduled race that I had an opportunity to participate in. At 11 a.m. approximately 20 percent of Saltillo's population, or roughly 40,000 people, decided that they were going to the motocross right now. Except that the entrance gate would only allow one vehicle at a time to enter. The traffic jam was five to seven lanes wide and two miles long; the race was to see who could maneuver around the overheated and out-of-gas cars and ace out the guy next to him. Every race was a photo-finish. Some, which involved anywhere from three to ten trucks, buses and cars, were highly reminiscent of a sport we have in the States called "destruction derby." The smart folks abandoned their cars and walked. A fiasco of this magnitude in the U.S. would have inspired dozens of hate letters to the promoter. In Mexico, it was a gas . . . repeated after the motocross was over, with a new contingency added to spice up the game: the drivers had been drinking beer non-stop for five hours. In the middle of the destruction derby stood Marco's comely wife, vainly attempting to direct traffic.

Allow me to insert some unrelated facts here that should help you reconstruct the scene at the motocross: 1) The track was 1 1/3 miles long, with plenty of steep ups and downs. 2) The many thousands of spectators were crammed 10-15 deep at some corners. 3) In Mexico there is a superstition which holds that anyone who touches someone defying death will himself defy death. This once widely held belief is becoming a victim of the 20th century, but there were still plenty of touchers in the audience. 4) The soldiers switched to sub-machine guns for the motocross. 5) Steve

*Continued*

**MOTOCROSS**

# MOTOCROSS ACTION

MX-4-1

## BACK ISSUES

Sept. 73  
Maico 450

Feb. 74  
Montana MX

Sept. 74  
Yamaha  
Motoshock

Nov. 74  
DeCoster at the  
U.S. Grand Prix

Jan. 75  
Elsinore  
Fork Kit

Oct. 73  
The GP Riders

March 74  
Biggest Race

Oct. 74  
Czech Nabs  
Super Bowl

Dec. 74  
125 World Cup

Feb. 75  
Magnetic  
Inspection

Nov. 73  
Yamaha YZ

April 74  
Combat Wombat

Dec. 73  
Marty Tripes  
Boy Wonder

May 74  
The Sang Gang  
Takes Over

Jan. 74  
Grand Prix

Aug. 74  
Roger DeCoster  
Interview

**MOTOCROSS ACTION Magazine**  
Back Issues Dept.  
Box 317, Encino, CA 91316

Circle issue desired. Enclose check or money order for 75¢ per issue plus 25¢ per issue for postage and handling. For issues after October '74, enclose \$1.00 plus 25¢ per issue.

NAME \_\_\_\_\_  
ADDRESS \_\_\_\_\_  
CITY \_\_\_\_\_  
STATE \_\_\_\_\_ ZIP \_\_\_\_\_

Enclose entire ad.

# PLUS PRODUCTS, INC. Tank, T & Sweatshirts

• COLORFUL  
• DURABLE  
MADE OF 100%  
PREMIUM COTTON

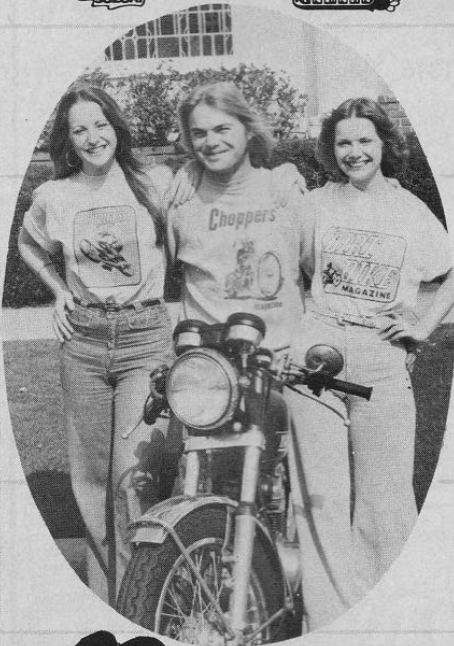

**PLUS PRODUCTS, INC.** MX-4-1  
 P.O. Box 14945 Las Vegas, Nevada 89114  
 Tank Shirt Colors: Orange, Yellow, Blue  
 T-Shirt Colors: White, Red, Yellow  
 Sweatshirt Colors: Red, Yellow, Blue, White  
 SIZES: S—M—L—XL  
 T-SHIRTS, \$4.45 with emblem on front. \$5.45 with emblem on both sides.  
 SWEATSHIRTS \$5.95. TANK SHIRTS \$3.95 with emblem on front. \$4.95 with emblem on both sides. Nevada residents add sales tax. Add 50¢ per shirt for postage and handling.

NAME \_\_\_\_\_  
 ADDRESS \_\_\_\_\_  
 CITY \_\_\_\_\_  
 STATE \_\_\_\_\_ ZIP \_\_\_\_\_



# NEW FOR 1975

# THE BEST OF DIRT BIKE TESTS

SPECIFICATIONS FOR ALL MODELS

**A MUST FOR ALL  
DIRT RIDING  
ENTHUSIASTS!**



## 1975 DIRT BIKE TESTS

P. O. Box 317, Encino, California 91316

Please send \_\_\_\_\_ copy(ies) of THE BEST OF DIRT BIKE TESTS. Enclosed is \$1.50 and 50 cents postage and handling for each copy ordered.

MX-4-1

### ORDER YOUR COPY TODAY!

**\$1.50** plus postage

Name \_\_\_\_\_  
 Address \_\_\_\_\_  
 City \_\_\_\_\_  
 State \_\_\_\_\_ Zip \_\_\_\_\_

## MEXICO

*Continued*

Stackable could have yelled "shit!" and several thousand people would have unbuckled their belts and looked for a big bush. 6) Motocross hero or not, Steve had to pay a \$40 bribe to get his bikes past Mexican customs.

After managing to suffer through the ordeal on the way to the track, the motocross itself seemed to be a contingency prize awarded to the survivors. In the first 250 moto, Priddy led for half the race, then yielded to Stackable. Wise was a very rapid fourth, Jones fifth. Jones dropped out with mechanicals; Wise passed Priddy; the race ended. Stack led the second 250 moto most of the way, then on the last lap Wise passed him for the overall win. Jones finished behind third place Wyman Priddy.

First Open moto (which in Mexico means anything from a moped to a Sportster): Stack all the way after a brief skirmish with Priddy, who ended up second with Jones third. Moto 2: Jones second behind Stackable, but both were beginning to show signs of extreme fatigue from riding two classes in the rarified mountain air. Bernie Thompson, Steve's mechanic, finished fourth overall in this class. It was only the fourth race in his entire, decadent life.

It would be easy to get corny here and tell you that Gran Premio is a wonderful weekend that only a fool would miss. But that's not true. You have to be able to roll with the punches and take things as they come. Plus you need empathy, a strong stomach and a pretty fair bankroll. If you come to Gran Premio with either none or all of the above, I assure you it will be a memorable event.

Independent News Co., Inc., is pleased to announce a Retail Display Plan available to all retailers interested in earning a display allowance on MX ACTION Magazine and who purchase the magazines from suppliers other than Independent News Co., Inc. To obtain details and a copy of the formal contract, please write to Director, Retail Sales Division, Independent News Co., Inc., 75 Rockefeller Plaza, New York, N.Y. 10019. Under the display plan, in consideration of your acceptance and fulfillment of the terms of the formal contract to be sent to you upon your request, you will receive a display allowance of ten percent of the cover price per copy sold by you. This plan will become effective with all issues of MX ACTION delivered to you subsequent to the date your written acceptance of the formal Independent News Co., Inc. Retail agreement is received and accepted by our company.

**MOTOCROSS**

# 1976 DIRT BIKE COLOR ACTION CALENDAR

12 Full Color  
Action Photos  
...Map of AMA  
Region locations ...  
Metric System Conversion Tables.

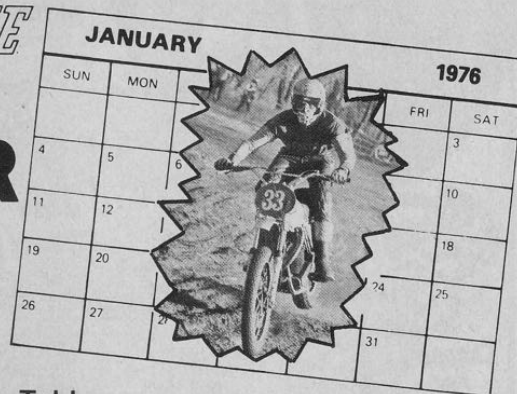

**The Calendar Dirt Enthusiasts wait for every year!**

**IT'S BETTER  
THAN EVER!**

And we even remembered to include the 1/4-inch hole for hanging.

**ONLY \$1.50**  
plus 50 cents postage

## DIRT BIKE CALENDAR

MX-4-1

P.O. Box 317, Encino, California 91316

Please send \_\_\_\_\_ Dirt Bike Calendar(s).

Enclose \$1.50 plus 50 cents postage for each Calendar ordered.

Name \_\_\_\_\_  
 Address \_\_\_\_\_  
 City \_\_\_\_\_  
 State \_\_\_\_\_ Zip \_\_\_\_\_

# PLUS PRODUCTS, INC.

**SPECTACULAR**  
Black & white  
**POSTERS**  
17" x 22"

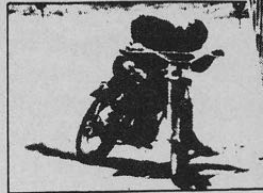

4. Slidin' Sideways



1. Airborne Yamaha



2. Drop-a-way jump



3. Wheelie on a Beezer

## PERSONALIZED WATCH



Your face hand painted on the dial. Send black and white or color photo.

**MAKES A TERRIFIC GIFT, TOO!**

DIAL SHOWN ACTUAL SIZE  
ALLOW 4 WEEKS FOR DELIVERY

Have your caricature with your type of bike on a sturdy watch. Eight illustrations to choose from.

- A. 1 yr. service warranty. **\$19.95**
- B. 17 jewel shock and water resistant. Gold tone case with stainless steel back. Two-year service warranty. **\$39.95**
- C. 17 jewel self-winding, shock and water resistant. Silver tone case with stainless steel back. Two-year service warranty. **\$44.95**

## STICKIES



Now you can show 'em where the action is! Put your Dirt Bike or Motocross Sticker on your gas tank, helmet or any unusual place that will make you stand out. Both stickies are 3-5/8" x 2-7/8". Only a mere 25 cents each, 5 for a buck, 1,000 for \$250, 10,000 for ?

## HYDRON-COATED GOGGLES



New coating of Miracle Plastic Hydron prevents fogging. Adjustable strap-fits everyone.

- No. 70 \$6.95
- No. 90 \$9.95 (wide angle)

## get it together binder



Tough durable binders for those dog-eared, priceless old back issues of Dirt Bike and Motocross Action Magazines. A rich finish with the name of the magazine embossed in gold on the front and on the spine.

**ORDER YOURS TODAY . . . DIRT BIKE and MOTOCROSS ACTION MAGAZINE BINDERS, very impressive on your desk or in your bookcase. Only \$4.45 each.**

## FLYWHEEL PULLERS GUARANTEED UNBREAKABLE



A flywheel puller - guaranteed for life - with a heat-treated center bolt. Order yours today and never be plagued with breakage again.

## Riders Special

### LONG WEARING PIGSKIN GLOVES



Extruded rubber knuckle and thumb protection. Seamless thumb for comfort. Sandstone color. Sizes small, medium, large and X-large.

**NOW ONLY \$6<sup>95</sup>**

# PLUS PRODUCTS, INC. P.O. Box 14945 Las Vegas, Nevada 89114

BE SURE TO INCLUDE ALL NECESSARY INFORMATION AND TO ENCLOSE CORRECT AMOUNT OF MONEY. Nevada residents add Sales Tax

MX-4-1

NAME \_\_\_\_\_  
ADDRESS \_\_\_\_\_  
CITY \_\_\_\_\_ STATE \_\_\_\_\_ ZIP \_\_\_\_\_

WATCH  Include Photo  
Indicate: Hair Color \_\_\_\_\_ Eye Color \_\_\_\_\_  
Name on Watch \_\_\_\_\_ Complexion \_\_\_\_\_

- DESERT RACER  CHOPPER A. \$19.95 \_\_\_\_\_ Watch(es)
- MX  DRAG RACER B. \$39.95 \_\_\_\_\_ Watch(es)
- ENDURO BIKE  STREET BIKE C. \$44.95 \_\_\_\_\_ Watch(es)
- MINI BIKE  CAFE RACER

Add \$1.00 for postage and handling for each watch ordered. Be sure to indicate how many watches and the bike desired on the dial.

FLYWHEEL PULLER \$8.95 plus 50¢ postage and handling.  
Model \_\_\_\_\_ Year \_\_\_\_\_

- Yamaha  Hodaka  Puch  Sachs
- Suzuki  Ossa  DKW  Bultaco
- Husky  Penton

- POSTERS**  
 \$1.50 each plus 50¢ for postage and handling  
 \$5.00 for -4- plus 50¢ for postage and handling
- BINDERS**   
 DIRT BIKE  
 MOTOCROSS ACTION  
\$4.45 plus \$1.00 postage for each binder ordered.
- GOGGLES**   
 #70 \$6.95  
 #90 (wide angle) \$9.95  
\$1.00 for postage and handling.
- PIGSKIN GLOVES**   
Indicate quantity \_\_\_\_\_ pair(s) and size(s) \_\_\_\_\_  
\$6.95 plus 50¢ postage and handling for each pair ordered.
- STICKIES**  25¢ each, 5 for a buck.  
 DIRT BIKE  
 MOTOCROSS ACTION



**MUD and  
CRUD and . . . .**

**. . . EXCITEMENT IN EVERY  
ACTION-PACKED ISSUE!**

If we have to say so ourselves, each issue of **MOTOCROSS ACTION** Magazine is better than the one before! Hey, really . . . check out our dynamite color photos, super coverage of your favorite motocross races (our favorites, too!), interviews with the top people in the motocross scene and our detailed product evaluations.

You owe it to yourself . . . subscribe today and save! Have **MOTOCROSS ACTION** delivered to you each month . . . **DON'T MISS A SINGLE ISSUE!**

**DO IT TODAY!**  
**SAVE \$3.00 ON  
12 ISSUES**  
**OR**  
**SEVEN BUCKS  
ON 24 ISSUES . . .**



P. O. Box 317  
Encino, California 91316

MX-4-1

All subscriptions outside the U.S., its possessions and Canada, add \$2.00 for postage.  
Save **\$3.00** on a 12 issue subscription, and **\$7.00** on a 24 Issue subscription.

\$9 – 12 issues

\$17 – 24 issues

Name \_\_\_\_\_

Address \_\_\_\_\_

City \_\_\_\_\_

State \_\_\_\_\_ Zip \_\_\_\_\_

**MOTOCROSS ACTION  
STATEMENT OF OWNERSHIP**

STATEMENT OF OWNERSHIP, MANAGEMENT AND CIRCULATION (An act of August 12, 1970: Section 3685, Title 39, United States Code.)

1. Date of filing: October 1, 1975.
2. Title of Publication: MOTOCROSS ACTION.
3. Frequency of issue: Monthly (semi-monthly in March, August).
4. Location of known office of publication: 16200 Ventura Boulevard, Suite 220, Encino, California 91436.
5. Location of the headquarters of general business offices of the publishers (not printers): 16200 Ventura Boulevard, Suite 220, Encino, California 91436.
6. Names and addresses of publisher, editor and managing editor: Publisher: William R. Golden, 16200 Ventura Blvd., Encino, California 91436; Editor: Dick Miller, 16200 Ventura Blvd., Encino, California 91436; Managing Editor: Mike Kerley, 16200 Ventura Blvd., Encino, California 91436.
7. Owner (if owned by a corporation, its name and address must be stated and also immediately thereunder the names and addresses of stockholders owning or holding one percent or more of total amount of stock. If not owned by a corporation, the names and addresses of the individual owners must be given. If owned by a partnership or other unincorporated firm, its name and address, as well as that of each individual must be given). Name of owners: William R. Golden and/or Raye Golden, 16200 Ventura Blvd., Encino, California 91436. Daisy Publishing Co., Inc., 16200 Ventura Blvd., Encino, California 91436.
8. Known bondholders, mortgagees, and other security holders owning or holding one percent or more of total amount of bonds, mortgages or other securities: None.
9. For optional completion by publishers mailing at the regular rates (Section 132.121, Postal Service Manual). 39 U.S.C. 3626 provides in pertinent part: "No person who would have been entitled to mail matter under former section 4359 of this title shall mail such matter at the rates provided under this subsection unless he files annually with the Postal Service a written request for permission to mail matter at such rates." In accordance with the provisions of this statute, I hereby request permission to mail the publication named in Item 1 at the reduced postage rates presently authorized by 39 U.S.C. 3626. (Signature and title of editor, publisher, business manager, or owner) Kass Massey, Circulation Director.
10. For completion by nonprofit organization authorized to mail at special rates (Section 132.122, Postal Manual): Not Applicable.
11. Extent and nature of circulation: A. Total number of copies printed (Net press run): average number of copies each issue during preceding 12 months: 150,690; actual number of copies of single issue published nearest to filing date: 146,974. Paid circulation: 1. Sales through dealers and carriers, street vendors and counter sales: Average number of copies each issue during preceding 12 months: 67,858; actual number of copies of single issue published nearest to filing date: 57,120. 2. Mail subscriptions: average number of copies each issue during preceding 12 months: 9,463; actual number of copies of single issue published nearest to filing date: 10,332. C. Total paid circulation: average number of copies each issue during preceding 12 months: 77,321; actual number of copies of single issue nearest filing date: 67,452. D. Free distribution (including samples) by mail, carrier or other means: average 1. Samples, complimentary, and other free copies: Average number of copies each issue during preceding 12 months: 311; actual number of copies of single issue published nearest to filing date: 275. 2. Copies distributed to news agents, but not sold: Average number of copies each issue during preceding 12 months: 72,248; actual number of copies of single issue published nearest to filing date: 78,437. E. Total distribution (sum of C and D): average number of copies each issue during preceding 12 months: 77,632; actual number of copies of single issue published nearest to filing date: 67,727. Office use, leftover, unaccounted, spoiled after printing: average number of copies each issue during preceding 12 months: 810; actual number of copies of single issue published nearest to filing date: 810. G. Total (Sum of E and F — should equal net press run shown in A): average number of copies each issue during preceding 12 months: 150,690; actual number of copies of single issue published nearest to filing date: 146,974. I certify that the statements made by me above are correct and complete. (Signature of editor, publisher, business manager, or owner): Kass Massey.

**CLASSIFIED**

RATES FOR READERS: 20 words for \$2.00; 25 cents each additional word. COMMERCIAL RATES: 30 cents per word: minimum \$10.00. Only one ad per advertiser permitted at these rates in any one edition; maximum of 50 words. No invoicing; payment must accompany orders, including firms on account with display advertising. No commissions, frequency rates or discounts. Ads accepted on the condition that advertiser agrees to refund reader's money promptly if shipment is delayed and reader requests refund, or if merchandise is returned (in good condition in reasonable period of time). Display style ads permitted in classified section at display advertising rates.

**3-RAIL MOTORCYCLE TRAILER** — amazing new design. Inexpensive and easy to build from scrap metal — no welding — bolt together. Plans, patterns only \$5.95. Order yours today — send check or money order to: C. HIETT, Dept. M1, Box 177, Lakewood, CA 90714.

**HOROSCOPE** — Your good points, bad points, lucky numbers. Your most compatible partners. Send \$2.00 and your birth date to "HOROSCOPE," Box 2635, Anaheim, CA 92804.

**INDEX TO ADVERTISERS**

Alliance American	15
American Motorcycle Institute	65
Bike Art	61, 66, 79
Change of Address	65
Comp Cross	62
Dirt Bike Calendar '76	74
Dirt Bike Coloring Book	62
Dirt Bike Photo Album	70
Dirt Bike Tests	74
DG Performance	9
Flying Machine Factory	7
Goodyear	10, 11
Honda of Piqua	67
How To Go Fast	70
How To Win At Racing	68
International Motocross Association	69
J & H Racing	15
JT Racing	63
Kawasaki	39, 40, 41, 42
Maico	13
Meyerscough Machines	64
Charles Miller Ltd.	80
Motocross Action Magazine	76
North American School of Motorcycle Repair	5
Number One Products	65
Pabatco/Hodaka	2
Plus Products	70, 71, 72, 73, 75
PK Racing Products	13
Rider's Choice	5
RV Van World	77
RV Van World Yearbook	64
Skunk Works	66
S & W Engineering	68
Trick Distributing	64
Trips Racing, Inc.	63
Village Togs	63
Jeff Ward Racing	61
Bill Waters Walters Leathers	66

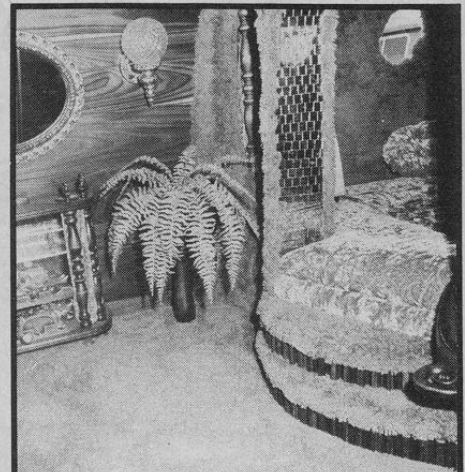

**RVAN WORLD  
MAGAZINE**

**... hey, it's really great! What do you want to know about vans?**

- Super paint jobs
- Cool custom interiors
- Van Happenings
- How-To's

**THEY'RE ALL THERE IN EVERY ISSUE OF RV VAN WORLD!**

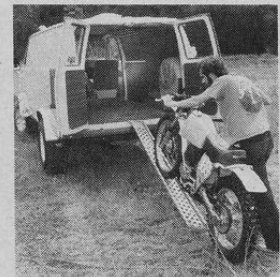

**WHETHER YOU RIDE IN THE STREET OR OFF-ROAD, YOU'LL LIKE WHAT WE HAVE.**

**RVAN WORLD** P.O. Box 317, Encino, California 91316

- \$9.00 - 12 issues
- \$17.00 - 24 issues

Enclose check or money order with coupon. Subscriptions outside the U.S., its possessions and Canada, add \$2 for postage. MX-4-1

Name \_\_\_\_\_  
Address \_\_\_\_\_  
City \_\_\_\_\_  
State \_\_\_\_\_ Zip \_\_\_\_\_

# BERM SHOT



*Another inch on those forks and he might have made it. He still went on to win both motos in the 250 Support race in Ravenna, Ohio. Bob Rutter the model, Gianatsis the photog.*

Honda CR-250M

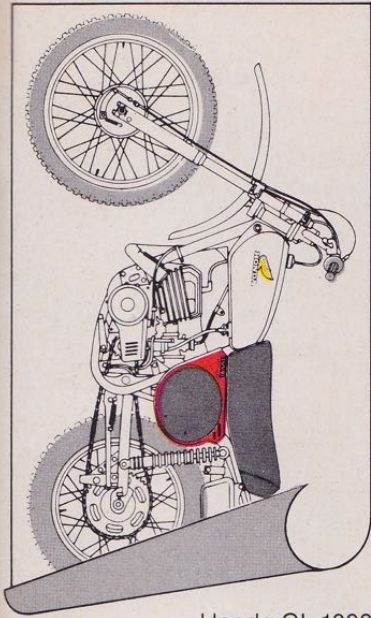

Suzuki RM-125

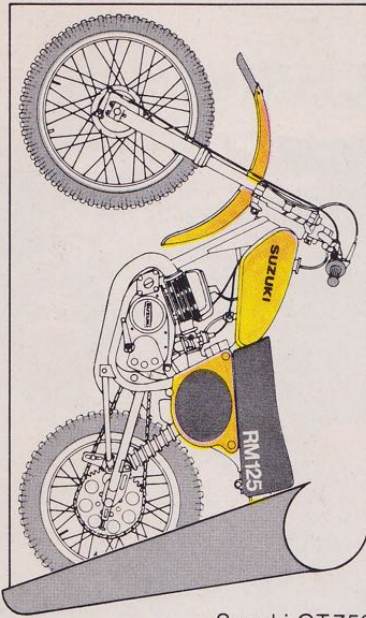

Yamaha MX-400

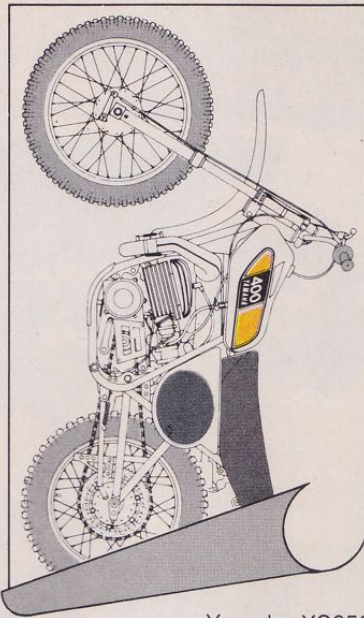

Kawasaki KX400

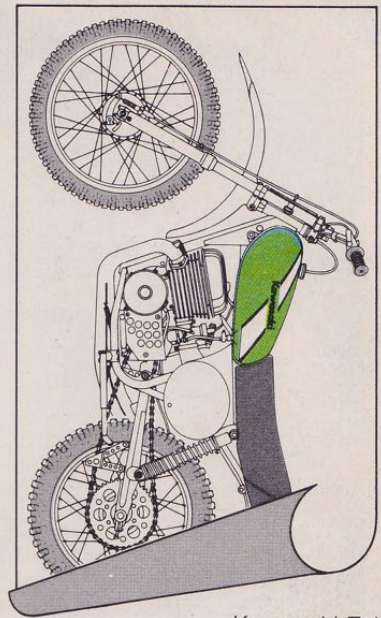

Honda GL-1000

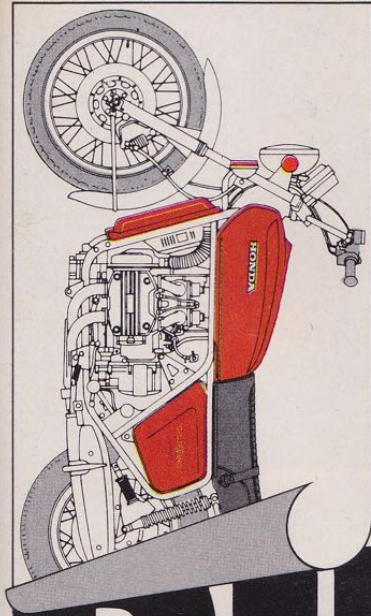

Suzuki GT-750

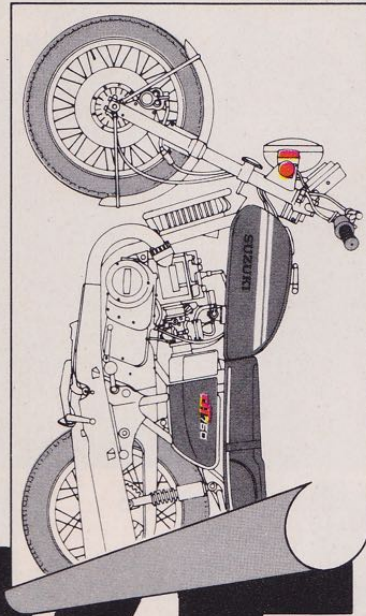

Yamaha XS650

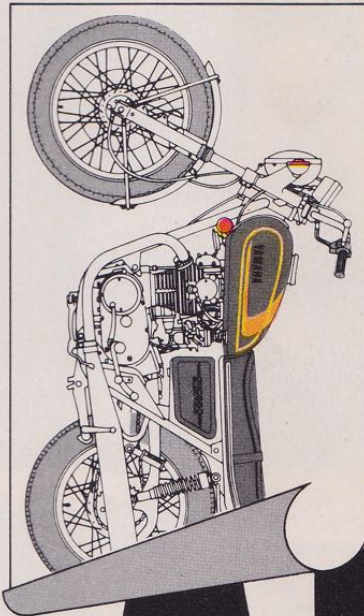

Kawasaki Z-1

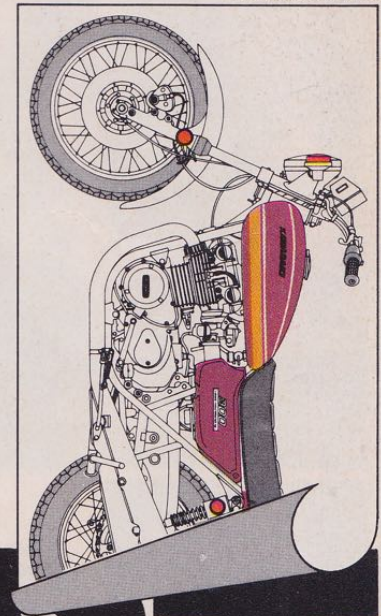

# BIKE ART

Send today for these big, full-color, super-detailed illustrated posters. Printed on fine quality art stock these posters are over 2 feet by 3 feet (25" x 38") and arrive ready for framing or hanging. Send check or money order (no COD's) for \$3.00 plus 50¢ postage for each poster – specify model – to: BIKE ART, P.O. BOX 20510, Dept. MA, Los Angeles, California 90006. California residents add 6% sales tax.

BIKE ART P.O. Box 20510, Dept. MA Los Angeles, California 90006

MX-1

Enclosed is check or money order for \$ \_\_\_\_\_

Poster: <b>Kawasaki: Z-1</b> _____	<b>KX400</b> _____	<b>Honda: GL-1000</b> _____	<b>CR-250M</b> _____
<b>Suzuki: GT-750</b> _____	<b>RM-125</b> _____	<b>Yamaha: XS650</b> _____	<b>MX-400</b> _____

Name \_\_\_\_\_

Address \_\_\_\_\_

City \_\_\_\_\_

State \_\_\_\_\_ Zip \_\_\_\_\_

\$3.00 each + 50¢ postage  
\$10.00 any 4 + \$1.00 postage  
\$20.00 all 8 + \$1.00 postage

Cal. residents add 6% sales tax.



# UNDER YOUR CHRISTMAS TREE



GREAT FOR  
MOTOCROSS  
TRAIL RIDING  
TRIALS  
ENDURO  
HARE & HOUND  
ISDT  
SCRAMBLES  
TT

RED  
LEATHERS

RED  
PIT TOOTSIE  
PANTS

MUNARI  
PIT TOOTSIE  
PANTS

MUNARI  
LEATHERS

BLACK  
PIT TOOTSIE  
PANTS

BLACK  
LEATHERS

NORSTAR  
PIT TOOTSIE  
PANTS

NORSTAR  
LEATHERS



ALSO AVAILABLE IN  
400 DENIER NYLON  
SAME QUALITY AT A  
LOW INTRODUCTORY PRICE

CHOICE TOP GRAIN  
IMPORTED PIG SKIN  
(MORE DURABLE THAN  
MOST OTHER HIDES)

"THE BREATHERS"  
SPANDEX GIVES YOU  
A THERMALLY CONTROLLED  
RIDE

GIVES A CUSTOM FIT, TOO  
DESIGN & USE, PAT. PEND.

SELF CENTERING  
KNEE CUPS

INSIDE POCKETS  
NO ZIPPERS TO JAM



MOTOCROSS  
DENIMS  
ADULT SIZES  
CHILDREN SIZES  
AND  
MATCHING  
DENIM JACKETS  
ADULT SIZES

GREAT FOR  
BICYCLE  
MOTOCROSS



HOT HOT HOT

TRIM  
LEATHER MATCHING  
PIT TOOTSIE PANTS

## AVAILABLE SIZES

	A	B	C	D
TRIM LEATHERS*	28-30	31-33	34-36	37-39
TRIM LEATHER	AA	BB	CC	DD
"PIT TOOTSIE" PANTS	22-24	25-27	28-30	31-33

\*ALSO AVAILABLE IN  
400 DENIER NYLON  
SAME QUALITY AT A  
LOW INTRODUCTORY PRICE

MOTOCROSS DENIMS	CHILDREN SIZES	ADULT SIZES
	5 6 7 8 10 12 14	28 30 32 34 36 38 40 42 44
DENIM JACKETS		34 36 38 40 42 44

ALLOW 15 DAYS FOR DELIVERY



NAME \_\_\_\_\_

ADDRESS \_\_\_\_\_

CITY \_\_\_\_\_ STATE \_\_\_\_\_ ZIP \_\_\_\_\_

MX-1	SIZE	STYLE	SALE	REGULAR
	WANTED	WANTED	PRICE	PRICE
TRIM LEATHERS	_____	_____	\$94.50	\$109.95
TRIM "PIT TOOTSIE PANTS"	_____	_____	*	29.95
* ONLY \$14.95 WITH PURCHASE OF ANY PAIR OF TRIM LEATHERS				
TRIM NYLONS	_____	_____	69.95	89.95
MOTOCROSS DENIMS	_____	_____	18.95	22.75
DENIM JACKETS	_____	_____	22.50	28.95

PLEASE INDICATE COLOR CHOICE FOR STRIPES \_\_\_ RED \_\_\_ YELLOW

ENCLOSED IS MY \_\_\_ CHECK \_\_\_ MONEY ORDER FOR TOTAL \$ \_\_\_\_\_

I WISH TO USE MY \_\_\_ BANKAMERICARD \_\_\_ MASTER CHARGE

AND MY NUMBER IS \_\_\_\_\_

SIGNED \_\_\_\_\_

NO C.O.D.S. PERSONAL CHECKS MUST CLEAR BEFORE WE WILL SHIP THE CLOTHING.

PLEASE ADD \$3.50 FOR POSTAGE, INSURANCE, AND HANDLING. FLA. RESIDENTS ADD 4% SALES TAX.

Charles Miller Ltd.

6730 142 AVE. NO.

LARGO, FLA. 33540

ACT NOW FOR CHRISTMAS DELIVERY!!